



Power Amplifier Series for Electrohydraulic Proportional Valve Drive

Overview

This special amplifier is for driving electro-hydraulic proportional pressure control valves, electro-hydraulic proportional flow control valves, and electro-hydraulic proportional direction control valves. It comes in a choice of two different types: an amp type and a controller type.

Basically, the amp type converts 0 to 10V DC range command voltage to a DC current in the range of 0 to 900mA, which is then supplied to the control valve.

The control type performs multi-stage control of output current in accordance with the ON-OFF signal of external contacts.

Power Amplifier Types and Functions

Type	Model No.	Drive Control Valve	Functions
Amp Type	EMA-PD5-N-20	Pressure Control Valves Flow Control Valves Direction Control Valves	Three functions: open loop control, feedback control, and acceleration/deceleration control.
Controller Type	EMC-PC6-A-20	Same as above.	Built-in command voltage setting units (potentiometers) Setting unit selection is performed by relay contacts, limit switches, timer contacts, etc.

Selecting a Power Amplifier

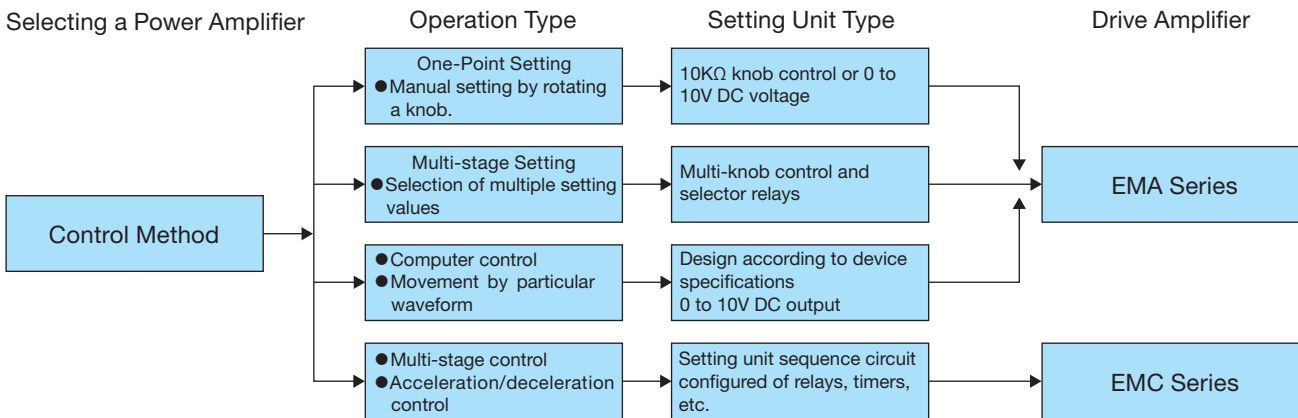

Specifications

Item	Model No.	EMA-PD5-N-20	EMC-PC6-A-20
Function		Amp Type (Closed Loop)	Controller Type
Number of Inputs		5 DC inputs	-
Number of Channels		-	6
Maximum Output Current		900mA (20Ω solenoid)	900mA (20Ω solenoid)
Input voltage		0 to +10V DC	-
Feedback Voltage		0 to +10V DC	-
Input Impedance		At least 50kΩ	-
Externally Set Variable Resistance		10kΩ	-
Zero Adjust(NULL)		0 to 900mA	0 to 900mA
Time Lag (T-UP, DOWN)		0.3 to 3sec	-
Gain Adjustment (GAIN)		$\frac{900mA}{10V_{DC}}$ to $\frac{900mA}{1.5V}$	0 to $\frac{900mA}{80\% \text{ channel setting}}$
External power supply		+10V _{DC} (10mA)	-
External Contact Resistance		-	10Ω max. when closed
Dither (Internal, semi-fixed)		Level: 0 to 500mAp-p Frequency: 50 to 220Hz	Level: 0 to 500mAp-p Frequency: 50 to 220Hz
Channel Time Lag (TIME)		-	0.3 to 3 seconds Externally variable
Power Supply Voltage		AC100, 110, 200, 220V (±10%)50/60Hz	AC100, 110, 200, 220V (±10%)50/60Hz
Power Consumption		50VA	50VA
Allowable Ambient Temperature		0 to 50°C	0 to 50°C
Temperature Drift		0.2mA/°C max.	0.2mA/°C max.
Weight		3.5kg	3.5kg

Explanation of model No.

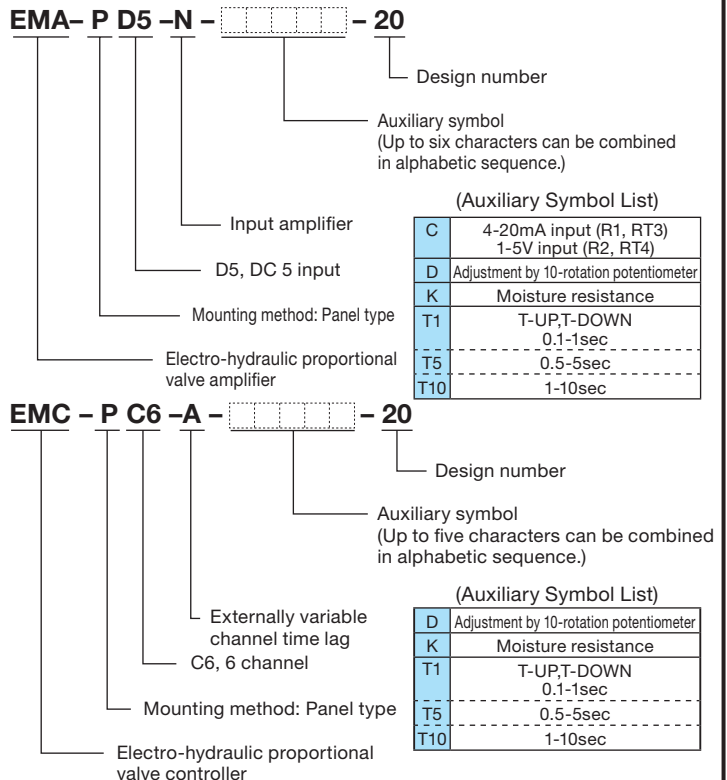

● Handling

- Power supply voltage can be either 100V or 200V.
- When selecting a location, avoid areas subject to high temperatures and high

- humidity, and select an area where there is little vibration and dust.
- Use shielded wire for the analog signal and valve output signal wires.

- When performing valve output signal line ON-OFF switching with a relay, connect a surge absorber or varistor parallel with the relay.

Note: T-UP, DOWN, and TIMER all become 0.3-3 sec when there is no signal for T1, T5, and T10.

Power Amplifier Series for Electro-hydraulic Proportional Valve Drive
EMA-PD5-N-20

No.	Name	No.	Name
1	R1, Input	8	Output terminal to VALVE COIL valve
2	R2, Input	9	FG, case ground
3	RT3, delay input	10	AC200, 220V
4	RT4, delay input	11	AC100, 110V
5	FB5, feedback input	12	
6	P10, external power supply	13	
7	COM, signal land	14	

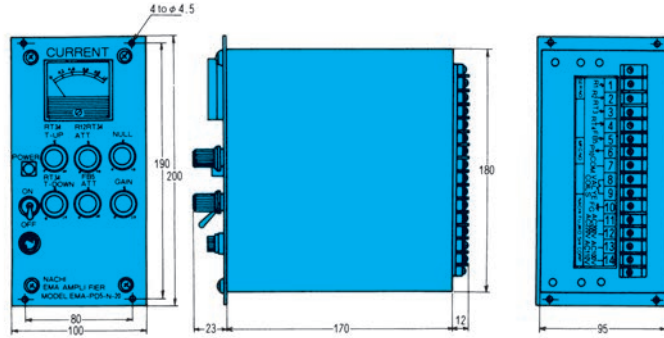
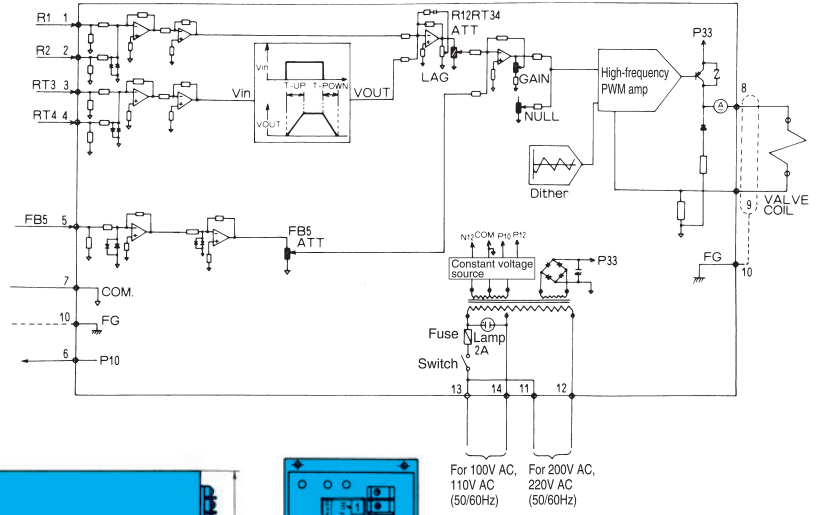

Application Examples

① Multi-stage Setting Using Multiple Potentiometers

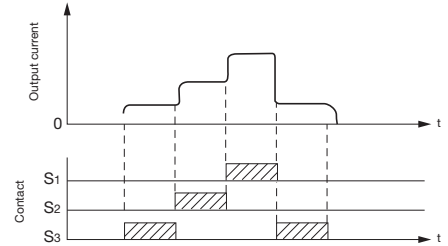
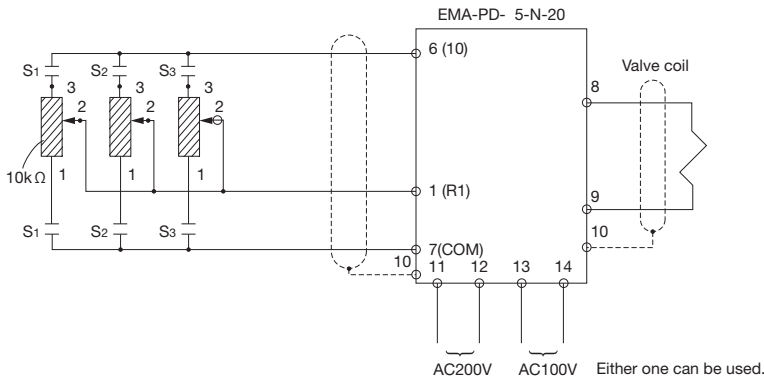

(1) Wiring the amp and external potentiometer

A potentiometer has three terminals numbered 1, 2, and 3.

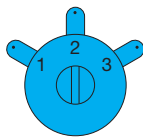

(2) Setting the adjusting knobs
Terminals 2 (R2), 3 (RT3), and 4 (RT4) can also be used in place of terminal 1. An RT34T-UP and RT34T-DOWN acceleration/deceleration timer can also be used in the case of terminal 3 (RT3) and terminal 4 (RT4).

In this case, the settings of the knobs on the front panel of the amp are normally as shown in the illustration below.

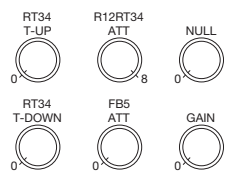

The manual setting unit provides output current control in the range of 0 to 900mA as it is rotated from full counterclockwise to full clockwise.

Wiring

- Amp terminal 7 (0V) Potentiometer terminal 1
- Amp terminal 6 (10V) Potentiometer terminal 3
- Amp terminal 1 (R1) Potentiometer terminal 2

With this wiring, rotating the potentiometer clockwise causes the output current to increase.

① If an output in the range of 0 to 600mA is desired even while the manual setting unit is rotated fully clockwise, restrict the setting of R12RT34ATT to 6.

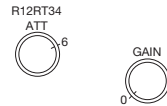

② When the level deceleration ratio and other factors limit the effective use of the manual setting unit to only 150° of the 300°, use GAIN to adjust the output current to 900mA.

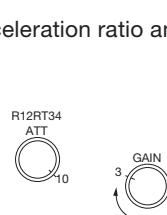

- Note) 1. A range of 5KΩ to 10KΩ is recommended for external knobs and potentiometers.
2. In order to prevent current loss across terminals 6 and 7, insert relays between terminal 6 and the potentiometers and terminal 7 and the potentiometers.
3. Do not enable more than one potentiometer at the same time.

(3) The following is available for the external setting knob.

Model No. FZS-6350-101

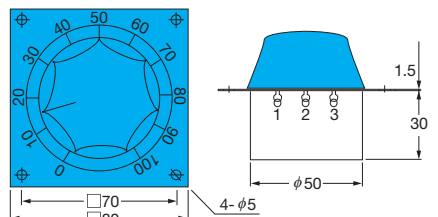

(4) Acceleration time adjustment (RT34T-UP) and deceleration time adjustment (RT34T-DOWN)

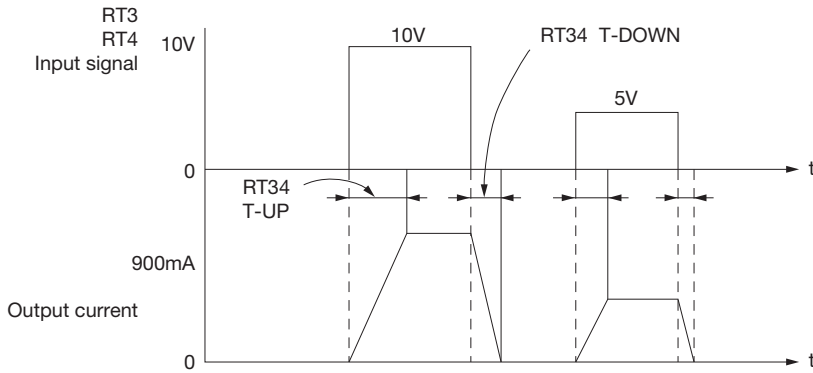

② Feedback Control.

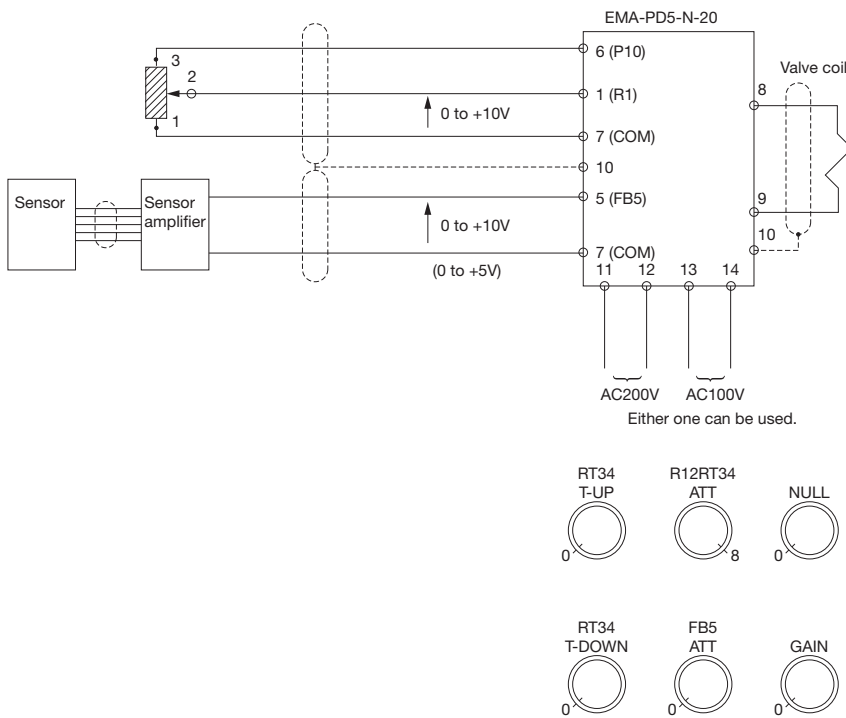

This circuit creates a fixed acceleration time lag in accordance with the voltage that added the input signal to terminals 3 and 4 (RT3, RT4). The time lag is adjustable in the range of 0.3 to 3 seconds, as standard. As shown in the diagram to the left, even when RT34T-UP is set to 3 seconds, the change to 5V during stepped input from 0 to 10V and stepped input from 0 to 5V takes 1.5 seconds, which is half the set time.

With the wiring shown to the left, output current is increased or decreased in accordance with the feedback signal of the sensor, which regulates pressure or the flow rate.

Note)

Using terminal 3 (RT3) and terminal 4 (RT4) in place of terminal 1 (R1) enables T-UP and T-DOWN, which allows feedback control without overshooting or undershooting, even when input signal voltage is stepped.

Adjustment Method

- ① Initially, set FB5ATT to 0 as shown in the illustration to the left, and check to see if open loop control is possible.
- ② Next, set FB5ATT to 2 and GAIN to 2, and input a feedback signal. Gradually rotate FB5ATT clockwise and increase gain. Set the feedback gain to the level that is immediately before the point where vibration is generated in the control system. (FB5ATT, GAIN)

Note)

1. To measure current, measure the voltage at terminal 9, using terminal 7 as reference. The voltage across the 0.5Ω current detection resistor at 1A is 0.5V. Use a measurement device with an input impedance of at least 1MΩ.
2. Switch the terminal 8 line using a relay. Make sure that both relays are not on at the same time.
3. To absorb surge voltage, include 82V varistors in parallel with the relay contacts.
Recommended Varistor
KOA NVD10SCD082
Panasonic ERZV10D820
4. For relays, use OMRON LY type power relays or the equivalent.
5. Too much noise in the 100V AC or 200V AC power supply line can result in unstable output current. If this happens, equip a surge absorber on the power supply.
Recommended Model
TDK NOISE FILTER
ZMB2201-13

③ Direction Control Valve (ESD) Drive

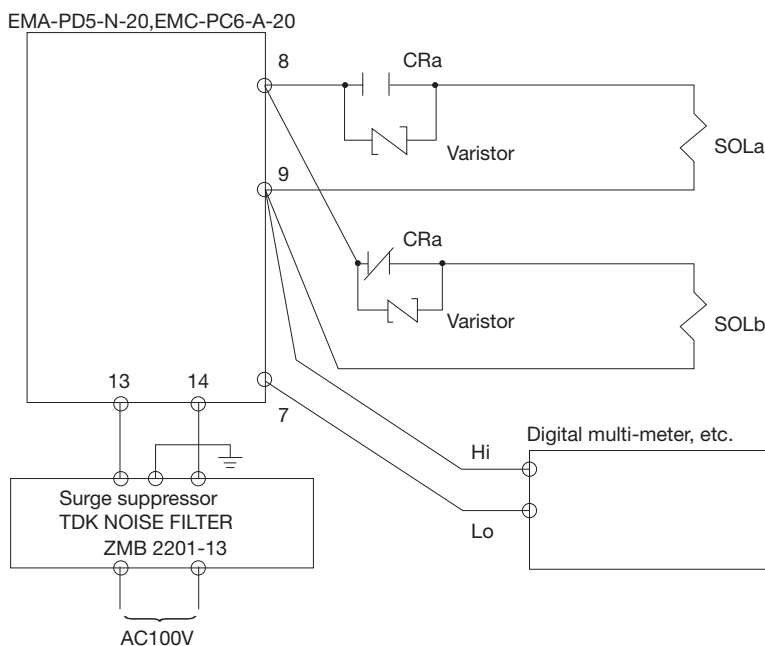

Power Amplifier Series for Electrohydraulic Proportional Valve Drive
EMC-PC6-A-20

No.	Name	No.	Name
1	CH1 Input command contact	8	Output terminal to valve
2	CH2 "	9	VALVE COIL
3	CH3 "	10	FG, case ground
4	CH4 "	11	AC200 220V
5	CH5 "	12	AC100 110V
6	CH6 "	13	AC100 110V
7	Common COM input contact	14	

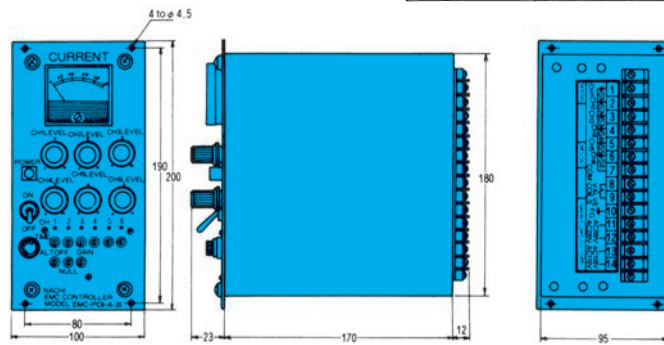
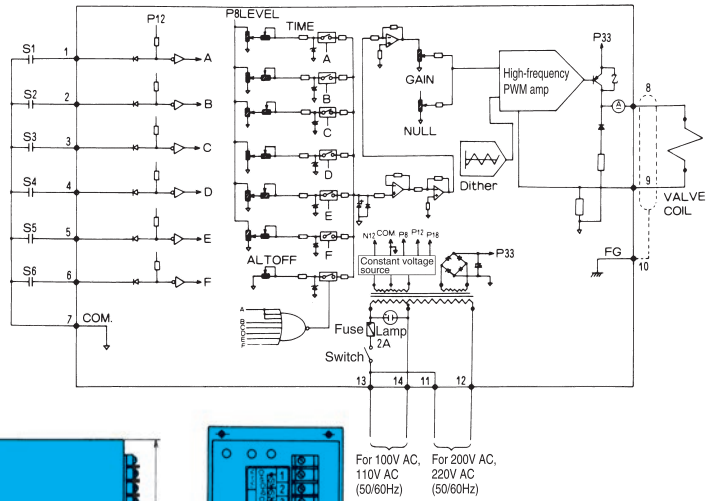

Note) When external contacts S1 through S6 are closed, use a non-voltage contact no greater than 10Ω.

Application

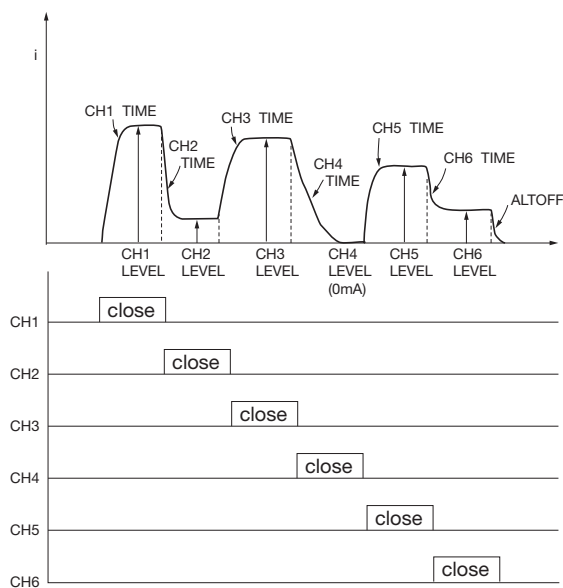

- LEDs are provided to indicate channel selection.
- The TIME knob of each channel adjusts the time until the selected channel's level is reached, as shown to the left. Make sure that the lap time (or time when channel is not selected) when changing the channel selection is 30msec maximum.
- Use independent external contacts. Even when external contacts are superimposed, output is not the sum of each channel, so use of superimposed external contacts is not supported.

Note) When replacing a Design Number 10 controller with a Design Number 20 controller, you must also change the sequence from superimposed external contacts to independent.

Dither Adjustment Method (Dither is set to load 400mAp-p, 100Hz.)

- (1) EMA-PD5-N-20 (2) EMC-PC6-A-20

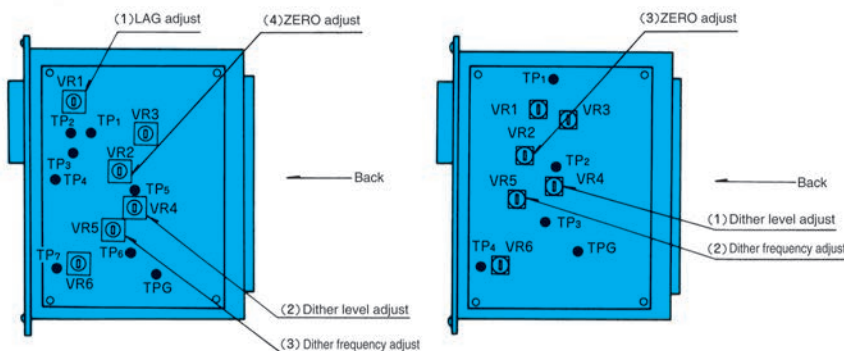

Removing the left side panel when viewed from the front reveals the configuration shown in the illustrations to the left.

- ① If piping or other items vibrate in response to the dither, raise the dither frequency by rotating the trimmer clockwise.
- ② When repeat stability is poor and the hysteresis is large, increase the dither level by rotating clockwise. If this does not resolve the problem, lower the dither frequency by rotating the trimmer counterclockwise.
- ③ When repeatability is poor with the ES valve or ESD valve due to insufficient air bleeding within the guide, raise the dither frequency by rotating the trimmer clockwise, as described in ①.