



Small Type Power Amplifier Series for Electro-hydraulic Proportional Valve Drive

Features

This power amplifier provides high efficiency and reliability in a compact configuration.

Lightweight, compact design –The configuration of this amplifier is 1/3 the weight and 1/2 the volume of existing models.

High efficiency –A PWM control system enables a highly efficient design with little heat generation.

High reliability –All functions are integrated onto a single circuit board for a highly reliable design with no internal wiring.

Specifications

Item	Model No.	EBA-PD1-N-C1-10	EBA-PD1-NW-C1-10	EBA-PD1-N(Z)-D2-10	EBA-PD1-NW(Z)-D2-10
Function		Amp Type (Open Loop)	Amp Type (Open Loop)	Amp Type (Open Loop)	Amp Type (Open Loop)
Number of Inputs		1 DC inputs	1 DC inputs	1 DC inputs	1 DC inputs
Drive Solenoid		SOL a	SOL a, SOL b	SOL a	SOL a, SOL b
Maximum Output Current		900mA (20Ω solenoid)	900mA (20Ω solenoid)	900mA (20Ω solenoid)	900mA (20Ω solenoid)
Input voltage		0 to +10V DC	-10 to +10V DC	0 to +10V DC	-10 to +10V DC
Input Impedance		50kΩ	50kΩ	50kΩ	50kΩ
Externally Set Variable Resistance		10kΩ	10kΩ	10kΩ	10kΩ
Zero Adjust		0 to 900mA	0 to 900mA	0 to 900mA	0 to 900mA
Gain Adjustment		0 to $\frac{900\text{mA}}{5\text{V input}}$	0 to $\frac{900\text{mA}}{5\text{V input}}$	0 to $\frac{900\text{mA}}{5\text{V input}}$	0 to $\frac{900\text{mA}}{5\text{V input}}$
External power supply		+5V DC (5mA)	+5V DC (5mA) -5V DC (5mA)	+5V DC (5mA)	+5V DC (5mA) -5V DC (5mA)
Dither Frequency		Variable: 80 to 220Hz	Variable: 80 to 220Hz	Variable: 80 to 220Hz	Variable: 80 to 220Hz
Time Lag		Internally Variable: 0.05 to 2 seconds	Internally Variable: 0.05 to 2 seconds	Internally Variable: 0.05 to 2 seconds	Internally Variable: 0.05 to 2 seconds
Power Supply Voltage		AC100 · 110V±10% (50/60Hz)	AC100 · 110V±10% (50/60Hz)	DC24V (DC24 to 30V)	DC24V (DC24 to 30V)
Power Consumption		30VA	30VA	30VA	30VA
Allowable Ambient Temperature		0 to 50°C	0 to 50°C	0 to 50°C	0 to 50°C
Temperature Drift		0.2mA/°C max.	0.2mA/°C max.	0.2mA/°C max.	0.2mA/°C max.
Weight		2.2kg	2.2kg	0.14kg (0.6kg with Z)	1.14kg (0.6kg with Z)
Driven Valve		Pressure Control Valves Flow Control Valves	Direction Control Valve	Pressure Control Valves Flow Control Valves	Direction Control Valve

● Handling

- 1 When selecting a location, avoid areas subject to high temperatures and high humidity, and select an area where there is little vibration and dust.
- 2 Use shielded wire for the analog signal and valve output signal wires.
- 3 The brightness of the LED changes in accordance with the size of the output current.

Explanation of model No.

EBA - PD1 - NWZ - D2 - 10

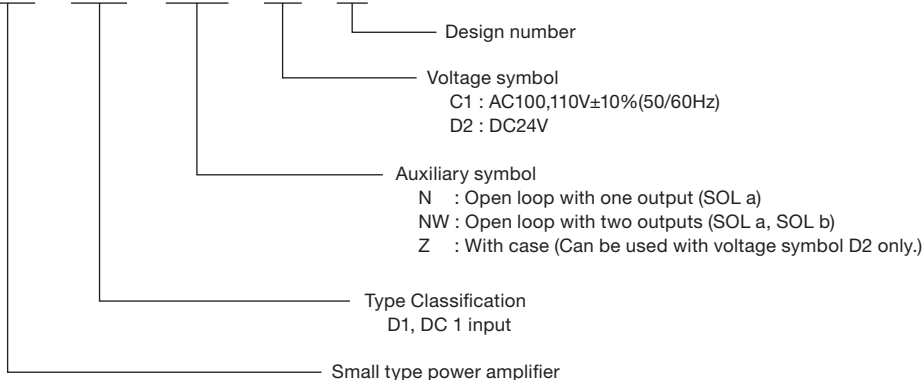

Installation Dimension Drawings

EBA-PD1-N-C1-10

No.	Name	No.	Name
1	Input signal terminal IN1	5	Output terminal to valve SOL a
2	Input signal terminal COM	6	
3	External power supply P5	7	
		8	
		9	
		10	AC100 · 110V

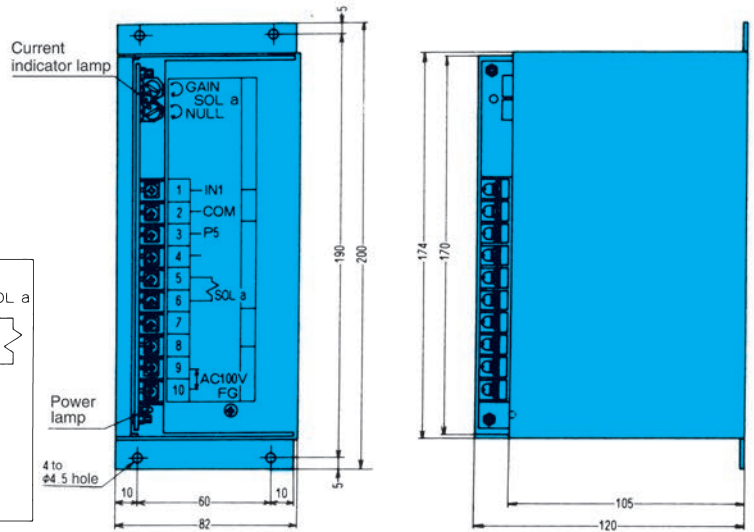
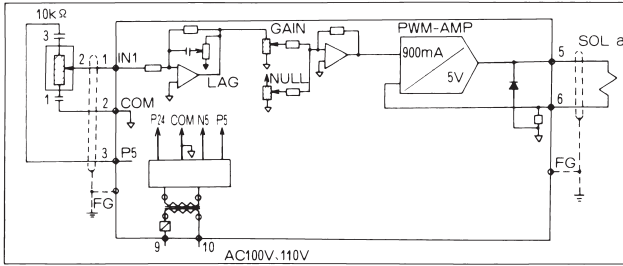

- With EBA-PD1-N (Z), current is supplied to the control valve in proportion to input signal voltage in the range of 0 to +10V.
- To measure current, measure the voltage at terminal 6, using terminal 2 as reference. The voltage across the 0.5Ω current detection resistor at 1A is 0.5V. Input impedance of the measurement device should be at least 1MΩ.
- With EBA-PD1-NW (Z), the polarity of the input voltage is determined, and current is supplied to SOLa when it's positive and to SOLb when it is negative.
- NULL and GAIN for SOL a and SOL b are enabled when each of their input signal voltage is ±0.1V or more.

EBA-PD1-NW-C1-10

No.	Name	No.	Name
1	Input signal terminal IN1	5	Output terminal to valve SOL a
2	Input signal terminal COM	6	
3	External power supply P5	7	Output terminal to valve SOL b
4	External power supply N5	8	
		9	
		10	AC100 · 110V

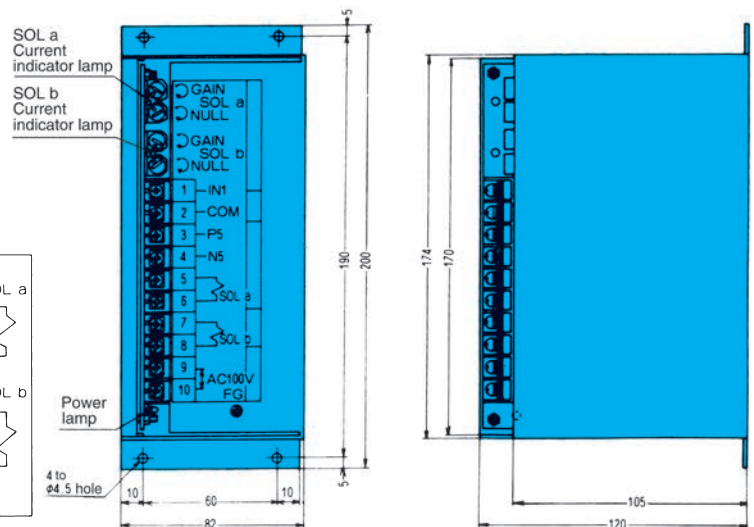
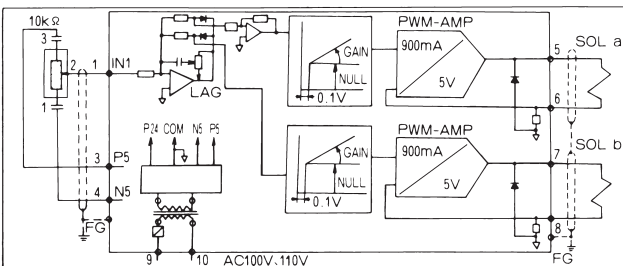

- To measure current, measure the voltage at SOLa terminal 6 and SOLb terminal 6, using terminal 2 as reference. The voltage across the 0.5Ω current detection resistor at 1A is 0.5V. Input impedance of the measurement device should be at least 1MΩ.

EBA-PD1-N(Z)-D2-10

No.	Name	No.	Name
1	Input signal terminal IN1	5	Output terminal to valve SOL a
2	Input signal terminal COM	6	
3	External power supply P5	7	
		8	
		9	+ DC24V
		10	- DC24V

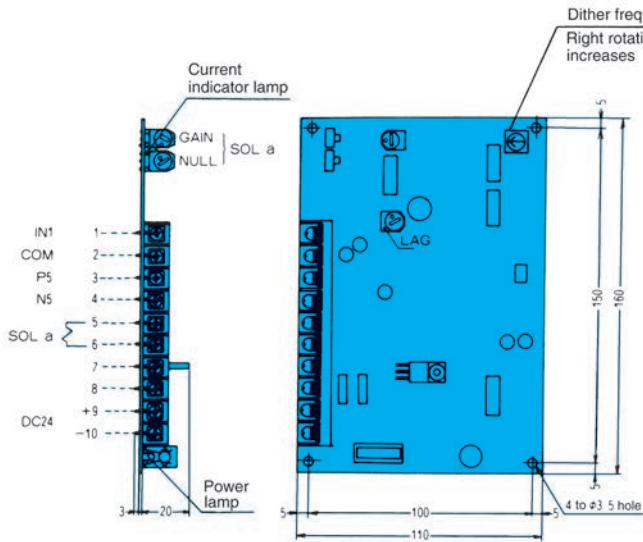
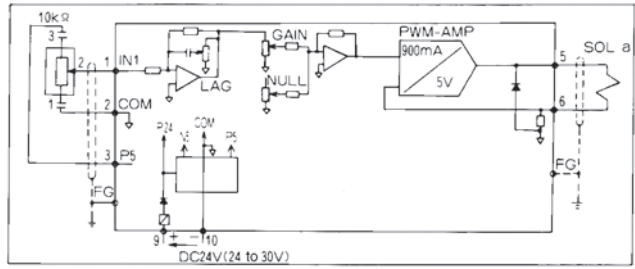

EBA-PD1-N-D2-10

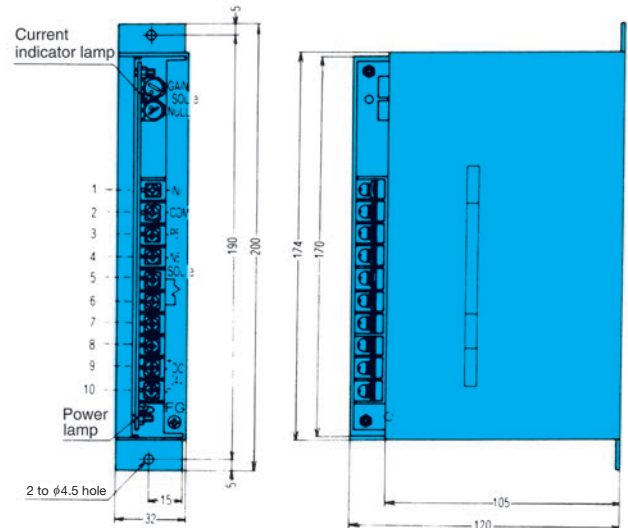

EBA-PD1-NZ-D2-10

EBA-PD1-NW(Z)-D2-10

No.	Name	No.	Name
1	Input signal terminal IN1	5	Output terminal to valve SOL a
2	Input signal terminal COM	6	
3	External power supply P5	7	Output terminal to valve SOL b
4	External power supply N5	8	
		9	+ DC24V
		10	- DC24V

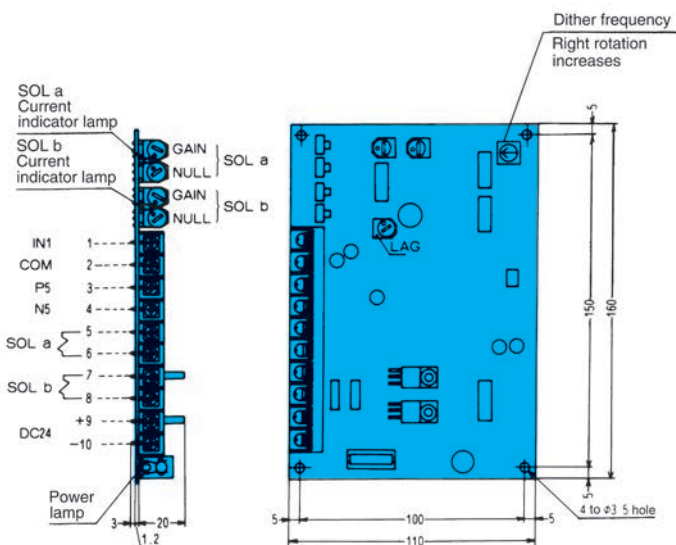
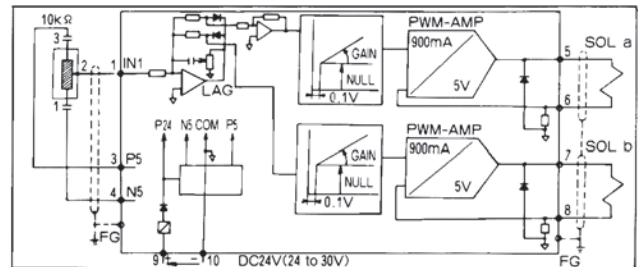

EBA-PD1-NW-D2-10

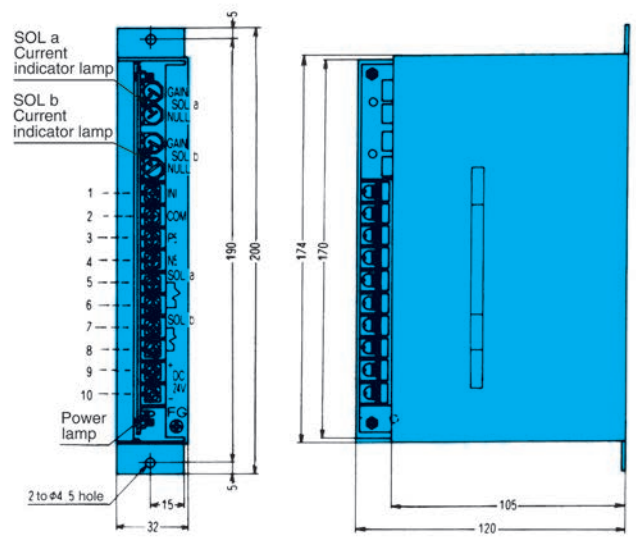

EBA-PD1-NWZ-D2-10

Note) Use a 24V switching regulator with a capacitance of at least 1A.

Example

Manufacturer	Model No.	Capacity
COSEL	R25A-24	24V 1.1A
TDK	EAK24-1R3G	24V 1.3A
DENSEI-LAMBDA	EWS25-24	24V 1.2A

● General Precautions

- Measuring current flow in the solenoid coil
As shown in the illustration below, disconnect the line supplying current to the solenoid coil, and then insert a 1A DC rated current meter or measure voltage across terminals 5 and 6. Solenoid coil resistance is 20Ω, so the relationship between voltage and current is as shown below. Note, however, that these values are not exact, because coil resistance changes with

Voltage (V)	Current (mA)
0	0
4	200
8	400
12	600
16	800

- Never energize only the solenoid coil.
The amp will not operate correctly if the iron coil is not inserted.

- For connection between the amp/controller and solenoid coil, use a 2-conductor shielded wire with a conductor nominal cross-section area of 2.0mm². Type VCTF (Rated Voltage: 300V vinyl cab tire cord). Wiring between the command voltage generator and amplifier should be VCTF 0.75m² 3-conductor wire. Use a shield that conforms to JIS Class 3 grounding. If the ground line is unstable, do not connect the shield to anything.

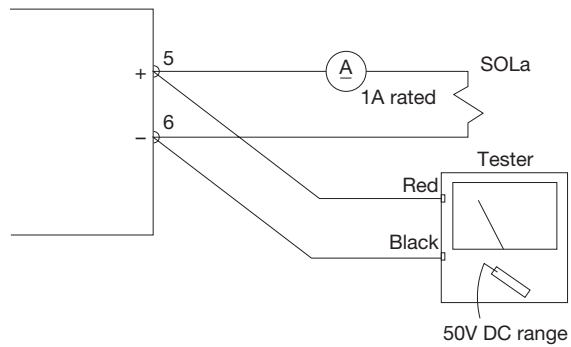

Power Amplifier Operation and Terminology

① Zero Adjust (NULL)

This knob sets the lower limit of the operating pressure and flow rate. Rotating it clockwise increases the output current. This knob is also used for manual control while checking valve operation.

③ Channel Time Lag (TIME)

This knob adjusts the time it takes for a channel selected by external contact to reach its channel level. Rotating it clockwise increases the time lag.

④ Dither

Dither plays a role in improving control valve hysteresis, response, stability, etc.

② Gain Adjust (GAIN)

This knob adjusts output current in proportion to input signal voltage or the channel level knob rotation angle. Rotating it clockwise increases gain.

