



NCP Series Standard Variable Pump Unit

NCP Series is a compact, low-cost standard unit that includes a variable vane pump (VDR, VDC Series) or a variable piston pump (PVS/PZS Series). The power unit is low-noise, low-heat, energy-efficient, and highly reliable. The NCP Series has been expanded to include a choice of models that are optimized for a very wide range of needs. Available tank capacities range from 30ℓ to 650ℓ.

Features

Low energy, high efficiency

A built-in low-noise, high-efficiency NACHI variable pump ensures low-heat, high-efficiency, low-energy operation.

A rich range of options

A full selection of options include base block, cooler, terminal box, microseparator, oil pan, return filter, and more, so you can configure a unit that meets your particular needs.

A selection of versatile circuits

Virtually any type of circuit can be configured using ganged type NACHI modular valves.

Low cost, short lead time

Components are all standard and mass produced, so parts are readily available at low prices.

● Handling

- All pump rotation is clockwise (rightward) when viewed from the shaft side.
- See the table below for information about adjusting discharge volume and pressure.
- For operating fluid, use regular oil equivalent to ISO VG 32 to 68 (Viscosity Index: 90 or greater).

	Adjusting Screw Rotation Direction	Pump type	
		VDC · PVS · PZS	VDR
Pressure	Clockwise	Increase	Decrease
	Counterclockwise	Decrease	Increase
Discharge rate	Clockwise	Decrease	
	Counterclockwise	Increase	

Specifications

- Note) ① For direct connect type, use a Nachi Uni-pump.
 ② Oil temperature limit is room temperature +25°C setting conditions are full cutoff continual operation, tank located in a well-ventilated area.
 ③ An unload circuit is required when the motor is started under condition λ-Δ. Contact your agent about the unload circuit.
 ④ Unless specified otherwise, electrical systems and paint colors are NACHI standards (see page L-13).

Variable Vane Pump Series

Power supply for all types is 200V AC.

Model No.	Pump Model No.	Connection	Motor (All External) kW, 4P	Tank Capacity ℓ	Full Cutoff Pressure at Tank Oil Temperature Limit (Note 3) MPa(kgf/cm ²)			Approximate Weight kg
					No Fan Cooler	With Standard Fan Cooler	With Highpower Fan Cooler	
(VC1A2) NCP-40-0.7VD1A2-□-13(22)	(VDC-1B-1A*-20) VDR-1B-1A*-22	Direct	0.75	40	3.0 (30.6)	8.0 (81.6)	—	75
(VC1A*) NCP-60-VD1A*-□-13(22)	(VDC-1B-1A*-20) VDR-1B-1A*-22	Direct	1.5 2.2 3.7	60	4.5 (45.9)	9.0 (91.8)	—	95 110 130
(VC1A3) NCP-100-3.7VD1A3-C-13(22)	(VDC-1B-2A3-20) VDR-1B-2A3-22	Direct	3.7	100	7.0 (71.4)	—	—	165
2A* NCP-160-VC2A*-□-13	VDC-2A-1A*-20 2A*	Coupling	5.5 7.5 11	160	3.5 (35.7)	6.5 (66.3)	8.5 (86.7)	255 265 315
2A* NCP-250-VC2A*-□-13	VDC-2A-1A*-20 2A*	Coupling	7.5 11 15	250	4.5 (45.9)	7.0 (71.4)	9.5 (96.9)	315 365 395
NCP-400-VC3A*-□-13	VDC-3A-1A*-20	Coupling	7.5 11 15 18.5 22	400	4.5 (45.9)	7.0 (71.4)	8.5 (86.7)	490 520 545 615 645
NCP-650-VC3A*-□-13	VDC-3A-1A*-20	Coupling	11 15 18.5 22 30	650	6.0 (61.2)	8.5 (86.7)	10.0 (102.0)	615 640 715 740 805

- Note) 1. Contact your agent when mounting motors enclosed in parentheses. These motors require special handling concerning operating pressure, heat generation, etc.
 2. Equip a return filter for pressures of 7MPa or greater.
 3. A radiator is equipped as standard with the 100ℓ type.

Variable Piston Pump Series

Power supply for all types is 200V AC.

Model No.	Pump Model No.	Connection	Motor (All External) kW, 4P	Tank Capacity ℓ	Full Cutoff Pressure at Tank Oil Temperature Limit (Note 3) MPa(kgf/cm ²)			Approximate Weight kg
					No Fan Cooler	With Standard Fan Cooler	With Highpower Fan Cooler	
NCP-30-PV8N*-R-13	PVS-0B-8N*-30	Direct	0.75 1.5	30	5.0 (51.0)	—	—	50 55
NCP-40-PV8N*-R-13	PVS-0B-8N*-30	Direct	0.75 1.5	40	5.0 (51.0)	21.0 (214.1)	—	80 85
NCP-60-PV8N*-R-13	PVS-0B-8N*-30	Direct	1.5 2.2 3.7	60	7.0 (71.4)	21.0 (214.1)	—	95 110 130
NCP-40-PV16N*-R-13(22)	PVS-1B-16N*-12	Direct	0.75 1.5	40	4.5 (45.9)	21.0 (214.1)	—	80 85
NCP-60-PV16N*-R-13(22)	PVS-1B-16N*-12	Direct	1.5 2.2 3.7	60	7.0 (71.4)	21.0 (214.1)	—	95 110 130
16 NCP-100-PV22N*-R-13(22)	PVS-1B-22N*-12	Coupling	3.7 5.5 7.5	100	8.5 (86.7)	21.0 (214.1)	—	155 185 200
NCP-160-PV35N*-R-13	PVS-2B-35N*-12	Coupling	5.5 7.5 11	160	7.0 (71.4)	14.0 (142.7)	21.0 (214.1)	250 260 310
NCP-250-PV45N*-R-13	PVS-2B-45N*-12	Coupling	7.5 11 15	250	9.5 (96.9)	17.0 (173.3)	21.0 (214.1)	310 360 390
NCP-400-PV70N*-R-13	PZS-3B-70N*-10	Coupling	7.5 11 15 18.5 22	400	5.5 (56.1)	14.0 (142.7)	16.0 (163.1)	505 540 565 635 660
NCP-650-PV70N*-R-13	PZS-3B-70N*-10	Coupling	11 15 18.5 22 30	650	8.5 (86.7)	16.0 (163.1)	18.0 (183.5)	635 660 735 760 825

Note) All models in this series are equipped with a return filter as standard.

NCP Series Selection Chart

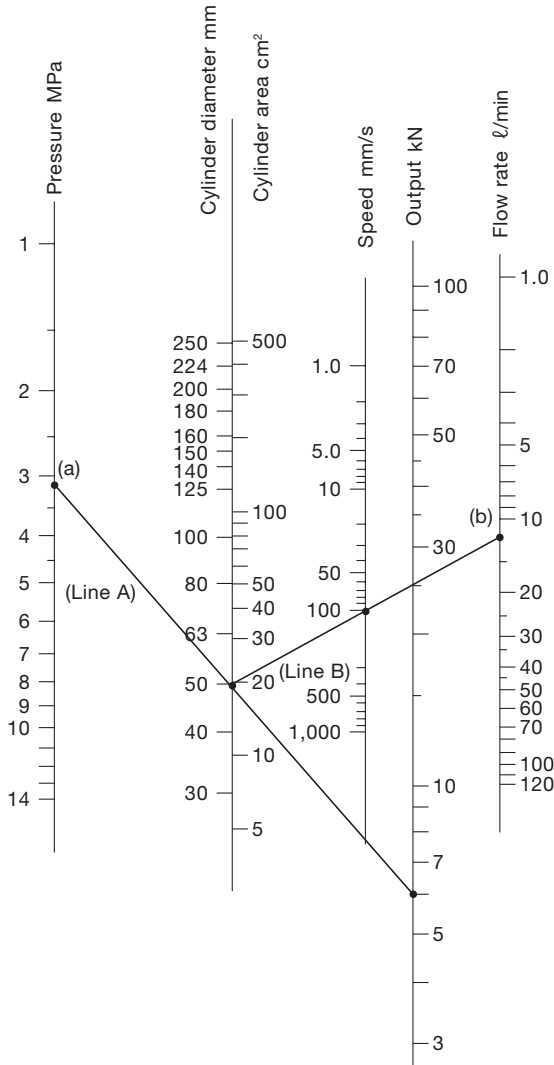

Flow rate ℓ/min	Area	Pressure MPa	NCP Series Model	
			Variable Vane Pump Series	Variable Piston Pump Series
5		3.5 to 5.0		NCP-30-0.7V8N1-R-13
10		4.5 to 8.0 8.0 to 14.0		NCP-40-1.5PV16N2-CR-13(22) -60-2.2PV16N2-CR-13(22)
15	50/60Hz	1.0 to 3.0 3.0 to 4.5 4.5 to 7.0 7.0 to 14.0	NCP-40-0.7V ^① A2-13(22) -60-1.5V ^① A3-13(22)	NCP-60-2.2PV16N1-R-13(22) -60-3.7PV16N2-CR-13(22)
20		1.0 to 3.0 3.0 to 5.0 5.0 to 10.0 10.0 to 14.0	NCP-40-0.7V ^① A2-13(22) -60-1.5V ^① A3-13(22)	NCP-60-3.7PV16N2-(C)R-13(22) NCP-100-5.5PV16N2-CR-13(22)
25	50Hz	1.0 to 3.0 3.0 to 5.0 5.0 to 12.0 12.0 to 14.0	NCP-60-1.5V ^① A2-13(22) -100-3.7V ^① A3-C-13(22)	NCP-100-5.5PV22N2-(C)R-13(22) -100-7.5PV22N2-CR-13(22) ★
	60Hz	1.0 to 3.5 3.5 to 5.0 5.0 to 12.0 12.0 to 14.0	NCP-60-1.5V ^① A2-13(22) -60-2.2V ^① A3-C-13(22)	NCP-100-5.5PV16N2-(C)R-13(22) -100-7.5PV16N2-CR-13(22)
30	50/60Hz	1.0 to 3.5 3.5 to 5.0 5.0 to 8.0 8.0 to 14.0	NCP-60-2.2V ^① A2-13(22) -100-3.7V ^① A3-C-13(22)	NCP-100-5.5PV22N2-(C)R-13(22) -100-7.5PV22N2-CR-13(22) ★
35	50Hz	2.0 to 7.0 7.0 to 10.5 10.5 to 14.0	NCP-160-5.5VC2A3-(C)-13	NCP-160-7.5PV35N2-CR-13 -160-11PV35N2-CR-13 ★
	60Hz	2.0 to 6.0 6.0 to 10.5 10.5 to 14.0	NCP-100-3.7V ^① A3-C-13(22)	NCP-100-7.5PV22N2-CR-13(22)
40		2.0 to 7.0 7.0 to 10.0 10.0 to 14.0	NCP-160-5.5VC2A3-(C)-13	NCP-160-7.5PV35N2-CR-13 -160-11PV35N2-CR-13 ★
50	50/60Hz	2.0 to 5.0 5.0 to 7.0 7.0 to 11.5 11.5 to 14.0	NCP-160-5.5VC ^② A3-(C)-13 -160-7.5VC ^② A3-C-13	NCP-160-11PV35N2-CR-13 -250-15PV45N2-CR-13
60	50Hz	2.0 to 7.0 7.0 to 10.0 10.0 to 14.0		NCP-250-7.5PV45N2-R-13 -250-11PV45N2-CR-13 -250-15PV45N2-CR-13 ★
	60Hz	2.0 to 4.5 4.5 to 7.0 7.0 to 10.0 10.0 to 13.5	NCP-250-5.5VC ^② A3-13 -250-7.5VC ^② A3-C-13	NCP-250-11PV35N2-CR-13 -250-15PV35N2-CR-13
75	50Hz	2.0 to 4.5 4.5 to 7.0 7.0 to 10.0 10.0 to 13.5	NCP-400-7.5VC3A3-13 -400-11VC3A3-C-13	NCP-400-15PV70N3-CR-13 -400-18.5PV70N3-CR-13 ★
	60Hz	2.0 to 5.5 5.5 to 8.0 8.0 to 11.0 11.0 to 13.5		NCP-250-7.5PV45N1-R-13 -250-11PV45N2-(C)R-13 -250-15PV45N2-CR-13 -250-18.5PV45N2-CR-13 ★
90	50/60Hz	2.0 to 4.0 4.0 to 6.5 6.5 to 9.0 9.0 to 11.5 11.5 to 13.5	NCP-400-7.5VC3A3-13 -400-11VC3A3-C-13	NCP-400-15PV70N3-CR-13 -400-18.5PV70N3-CR-13 -400-22PV70N3-CR-13 ★
100	50Hz	2.0 to 6.0 6.0 to 8.0 8.0 to 10.0 10.0 to 12.0 12.0 to 14.0		NCP-650-11PV70N1-R-13 -650-15PV70N3-R-13 -650-18.5PV70N3-CR-13 -650-22PV70N3-CR-13 -650-30PV70N3-CR-13
	60Hz	2.0 to 6.0 6.0 to 8.0 8.0 to 10.0 10.0 to 12.0 12.0 to 14.0	NCP-650-11VC3A3-13	NCP-650-15PV70N3-R-13 -650-18.5PV70N3-CR-13 -650-22PV70N3-CR-13 -650-30PV70N3-CR-13
110	60Hz	2.0 to 5.5 5.5 to 7.0 7.0 to 9.0 9.0 to 11.0 11.0 to 14.0	NCP-650-11VC3A3-13 -650-15VC3A3-(C)-13	NCP-650-18.5PV70N3(C)R-13 -650-22PV70N3-CR-13 -650-30PV70N3-CR-13
120	60Hz	2.0 to 5.0 5.0 to 7.0 7.0 to 8.5 8.5 to 10.0 10.0 to 13.5		NCP-650-11PV70N1-R-13 -650-15PV70N3-R-13 -650-18.5PV70N3-R-13 -650-22PV70N3-CR-13 -650-30PV70N3-CR-13

[Example]

To determine the NCP Series model that drives a $\phi 50$ cylinder with an output of 6kN and speed of 100mm/s.

(a) Draw a line (Line A) between 6kN on the output line and the $\phi 50$ point on the cylinder diameter line. Extend Line A until it intersects with the pressure line at Point (a). Though Point (a) indicates a pressure of 3.1MPa, we need to add about 1MPa to compensate for pressure loss due to piping and other factors, so a pressure of 4MPa is required.

(b) From the $\phi 50$ point on the cylinder diameter line, draw a line (Line B) to the 100 mm/s point on the speed line. Extend Line B until it intersects with the flow rate line at Point (b), which indicates a required flow rate of 11.8 ℓ/min.

(c) Based on the required flow rate of 11.8 ℓ/min. and required pressure of 4MPa obtained above, we can now check the selection chart where we easily find out that the required model is NCP-60-1.5VD1A3-13. Next, select the required option from Table 1 on the following page.

- Note)
- Contact your agent if you need a low-pressure NCP unit with piston pump.
 - If flow rate and pressure are not specified, products are configured with company standard settings before shipping.
 - When running items marked with a star (★) to the right of the table for long periods at pump setting pressure, oil temperature may exceed 60°C even when a fan cooler is used. In this case, use a water cooler.
 - Contact your agent for applications where there is the chance of frequent momentary return flow due to the use of ACC, or surge voltage generated due to the use of fast switching valve response and a high cycle.

Explanation of model No.

NCP - 100 - 3.7 ***** - - 13(22)

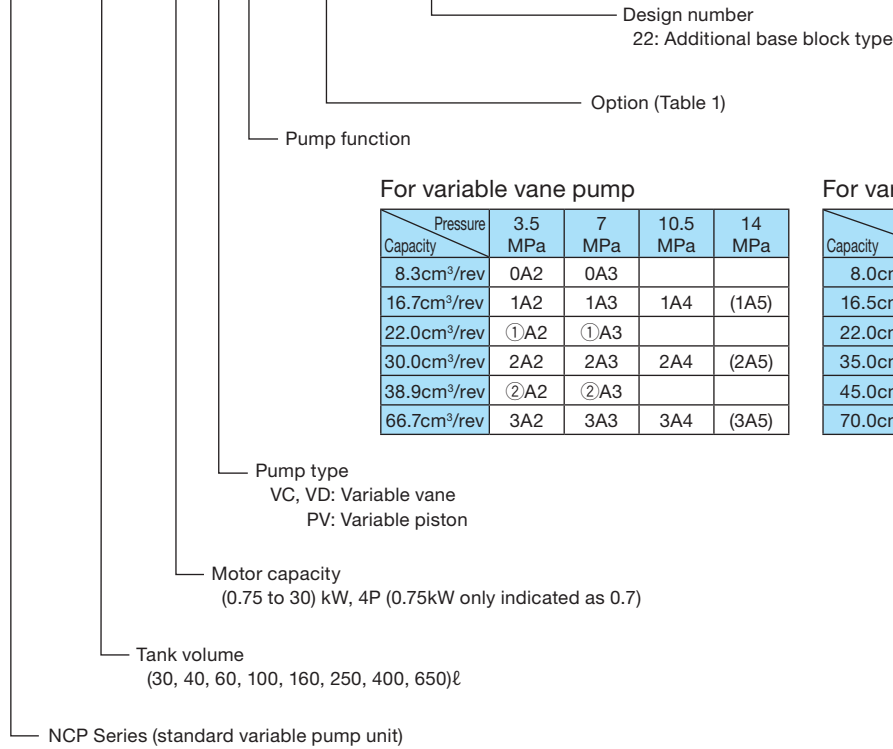

For variable vane pump

Capacity	Pressure 3.5 MPa	7 MPa	10.5 MPa	14 MPa
8.3cm ³ /rev	0A2	0A3		
16.7cm ³ /rev	1A2	1A3	1A4	(1A5)
22.0cm ³ /rev	①A2	①A3		
30.0cm ³ /rev	2A2	2A3	2A4	(2A5)
38.9cm ³ /rev	②A2	②A3		
66.7cm ³ /rev	3A2	3A3	3A4	(3A5)

For variable piston pump

Capacity	Pressure 2 to 7MPa	7 to 14MPa
8.0cm ³ /rev	8N1	8N2
16.5cm ³ /rev	16N1	16N2
22.0cm ³ /rev	22N1	22N2
35.0cm ³ /rev	35N1	35N2
45.0cm ³ /rev	45N1	45N2
70.0cm ³ /rev	70N1	70N3

Table 1: Option Symbols

Symbol	Description	Model Number and Description	30L	40 to 100L	160, 250L	400, 650L
B	Base Block (Design No. 13 Only)	MPU Series built-in	○ ^{Note 2}	○	○	○
C	Radiator	N13F-001-1050	○	○		
C1	General-purpose Fan Cooler	3A92-001-0000 16/15W Single-phase 200V AC 50/60Hz		○	○	○
C2	High-power Fan Cooler	3A92-002-0000 35/30W Single-phase 200V AC 50/60Hz			○	○
D	Terminal Wiring (Drive System + Control System)	Wiring from each electrical device to the terminal box (Drive System + Control System)	○	○	○	○
E	Terminal Wiring (Control System Only)	Wiring from each electrical device to the terminal box (Control System Only)	○	○	○	○
F	Mounting Foot for Forklift	See mounting foot for forklift specifications.		○		
M	Microseparator	TMG-1S(to100L), TMG-2ZS(160L to)	○	○	○	○
N	Noise Control	Motor 6P specifications				○
P	Oil pan	See oil pan specifications.		○	○	○
R	Return Filter	WS-20-20-V(20μ paper)	○			
R1	Return Filter	CF-0*(10μ paper) FRS-**-20P**(20μ paper)		○ ^{Note 3}	○ ^{Note 3}	○
R2	Return Filter	FPL-**(10μ paper)		○	○	
T	Temperature Gauge (With Fluid Level Gauge)	φ6 × 80L (0 to 100°C) with guard φ8 × 120L (-20 to 100°C) with guard	○	○	○	○
V	Vibration Control	Anti-vibration rubber, rubber hoses, etc.				○
W1	Self Leak Test	Tank leak test by NACHI		○	○	○
W2	Government-mandated Leak	Test Tank leak test by fire department		○	○	○
TH	Thermostat (Abnormal oil temperature detection: Contact a)	TNS-C1070C (Contact on: 65°C and above)		○	○	○
PS	Pressure Switch (Abnormal pressure detection: Contact a)	CE** Contact ON: (Pump Setting Pressure)-(1.5MPa) and above		○	○	○
FS	Float Switch (Low fluid level detection: Contact a)	OLV-2A Contact on: (Fluid Level Gauge Visual Low Level)-(10mm) or less		○	○	○
G	Fluid Level Gauge Guard	Protective cover installation	○	○	○	○
R3	Return Filter (Tank Top Type)	MAR**-**P-S				
L	Anchor Hole Outer Side	Anchor hole set on outer side				
	Motor Voltage Overseas	Reference Voltage Other than 200V AC 50/60Hz; 220V AC 60Hz				
	Special Paint (Exterior)	Other than standard lacquer paint (phthalates, epoxy, etc.)				
	Piston Pump Variable Control Option	Other than standard control system N (NQ, RS, WS, RQS, etc.)				
	Fire Resistant Operating Fluid (W/G Type)	Water- or glycol-based hydraulic operating fluid (Contact your agent about other fluid types.)				
	Water Cooler	When capacity of pump DR fan cooler is insufficient				
	Electric Oil Heater	When there is the possibility of fluid pressure dropping below 0°C				

- Note) 1.Design 13 when option symbol B is selected. (Base block additional 22 design is not applicable)
 2.With the optional Symbol B capacity 30L, a special base block can be used in a configuration of up to 01 × 3.
 3.Option symbol R1 CF-0* is applicable to pump functions *A2 and *NO only.
 4.FRS-08-20P08T for option symbol R1, capacity 250L using a 45cm³/rev type.
 5.Contact Nachi for information about design number 5100*.

Table 2 The upper and lower limit of the NCP series tank hydraulic fluid level

Tank capacity [L]	Upper limit of hydraulic fluid level [L]	Lower limit of hydraulic fluid level [L]
30	30	24
40	40	31
60	60	49
100	100	80
160	160	111
250	250	184
400	400	306
650	650	522

Selecting a Motor

- The lower side of the output curves for each of the motors shown in the graph indicates the operating range under rated output for that motor.
- Standard voltage for drive motor is 200 VAC, 50/60 Hz or 220 VAC, 60 Hz.

Example: To find the motor that can produce pressure of 3.5MPa {35.7kgf/cm²} and a discharge rate of 25ℓ/min.

Since the intersection of the two broken lines from a pressure of 3.5MPa {35.7kgf/cm²} and discharge rate of 25ℓ/min intersect in the area under the 2.2kW motor should be used.

For variable vane pump

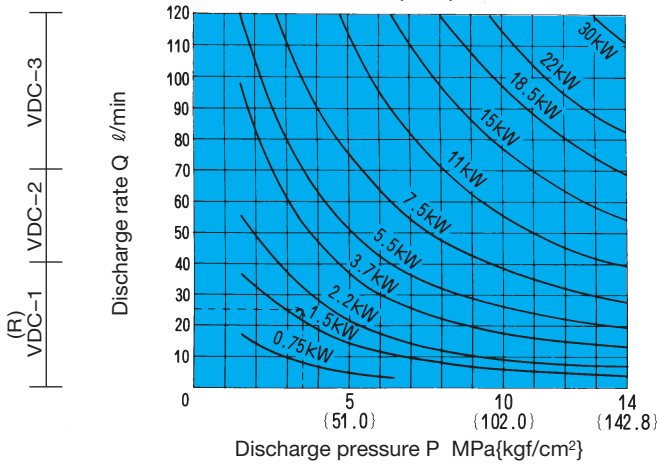

For variable piston pump

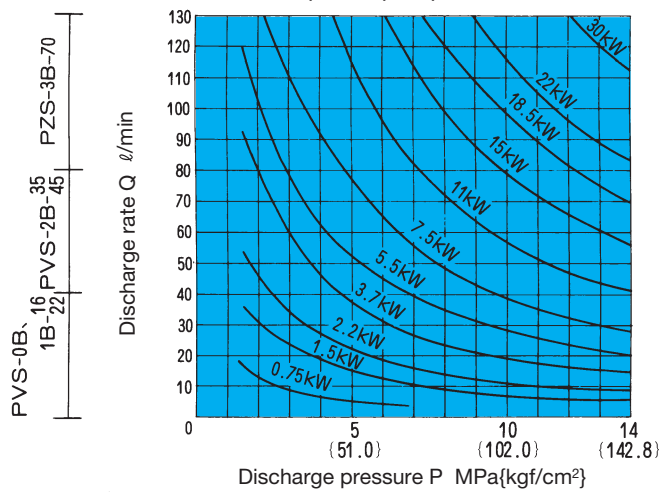

Installation Dimension Drawings

(Note) Catalog dimensions, layout, and used devices are subject to change without notice. In particular, be sure to check in cases where dimensions are limited.

● Mini NCP Series
NCP-30-**PV8N*-*-13

● Option item numbers are colored.

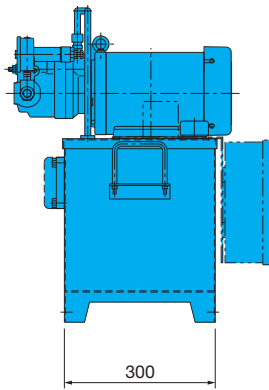
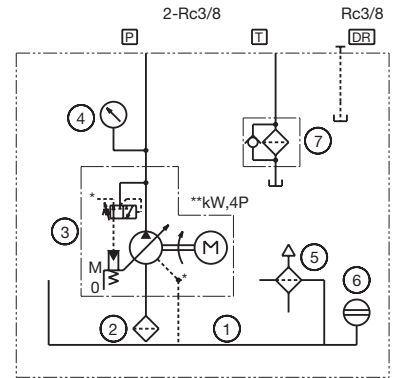
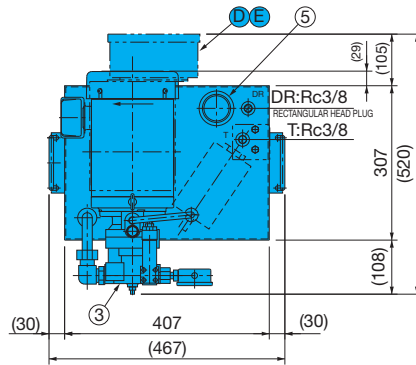

Auxiliary View P

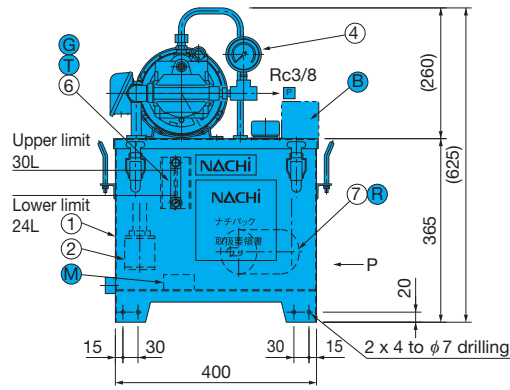

Part No.	Name	Model No.	Q'ty
1	Tank	30ℓ	1
2	Strainer	CS-06(150 mesh)	1
3	Uni-pump	UPV-0A-8N*-**A-4-50	1
4	Pressure gauge	GV50-173x**MPA	1
5	Fluid supply port/air breather	MSA-V30	1
6	Fluid level gauge	φ6×80L	1
7	Return filter	WS-20-20-V	1

NCP-40-0.7V_D⁰1A2*-13

NCP-60-**V_D⁰1A*-13

Symbol	Dimensions (mm)	
	40ℓ	60ℓ
LA	625	725
LB	560	660
LC	510	610
LD	350	440
LE	675	765
LF	290	380
LG	300	350
LH	590	640
LI	31	33

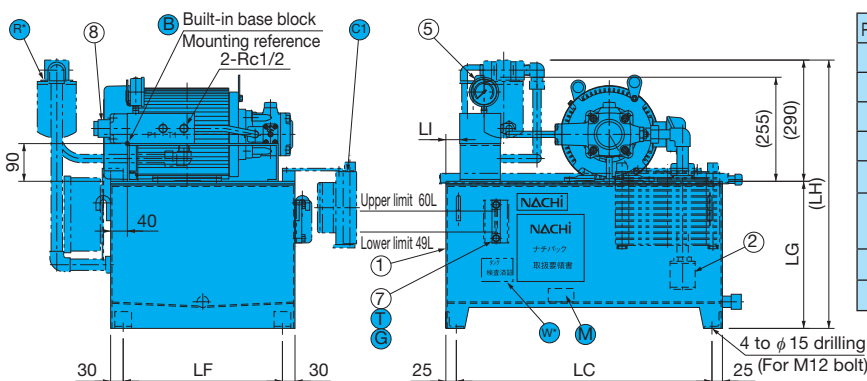
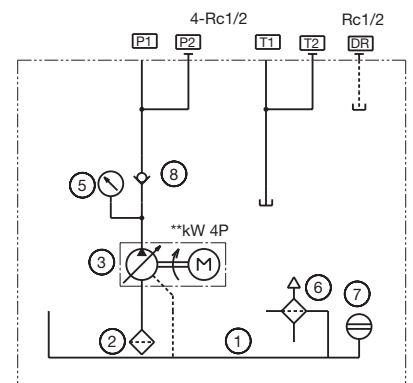
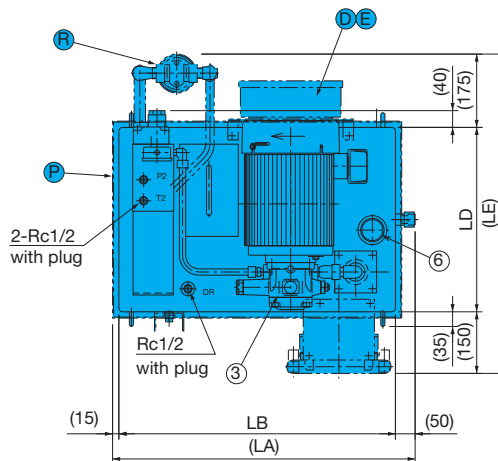

Part No.	Name	Model No.	Q'ty
1	Tank	**ℓ	1
2	Strainer	CS-06(150 mesh)	1
3	Uni-pump	UVC(D)-1A-A*-**A-4-40(60)	1
4			
5	Pressure gauge	GV50-173x**MPA	1
6	Fluid supply port/air breather	MSA-V30	1
7	Fluid level gauge	φ6×80L	1
8	Check valve	CA-G03-1-20	1

NCP-100-3.7V_D1A3-C-13

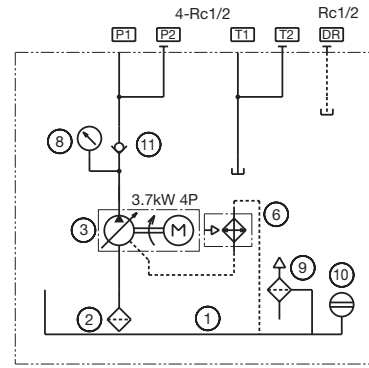
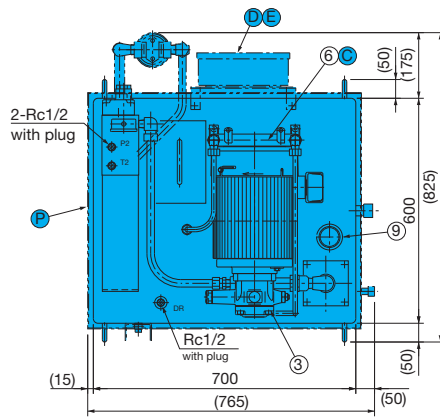

Part No.	Name	Model No.	Q'ty
1	Tank	100ℓ	1
2	Strainer	CS-08(150 mesh)	1
3	Uni-pump	UVC(D)-1A-2A3-3.7-4-40(60)	1
4			
5			
6	Radiator	3A92-001-1050	1
7			
8	Pressure gauge	GV50-173x**MPA	1
9	Fluid supply port/air breather	MSA-V30	1
10	Fluid level gauge	φ6x80L	1
11	Check valve	CA-G03-1-20	1

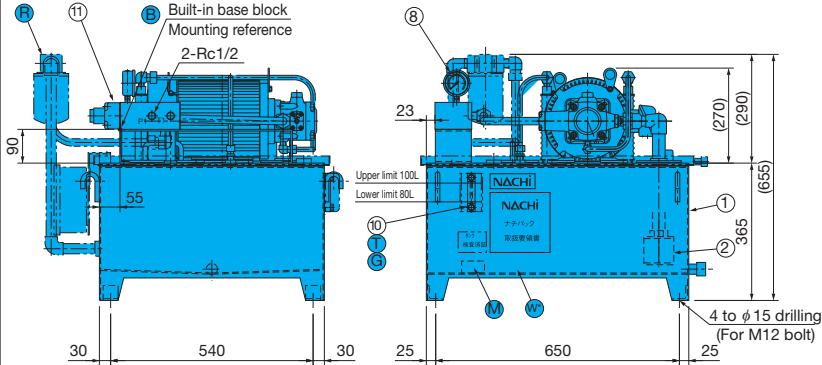

NCP-40-0.7VD1A2*-22
NCP-60-**VD1A*-22

Symbol	Dimensions (mm)	
	40ℓ	60ℓ
LA	605	705
LB	560	660
LC	510	610
LD	350	440
LE	460	550
LF	290	380
LG	580	630
LH	300	350
LI	31	33

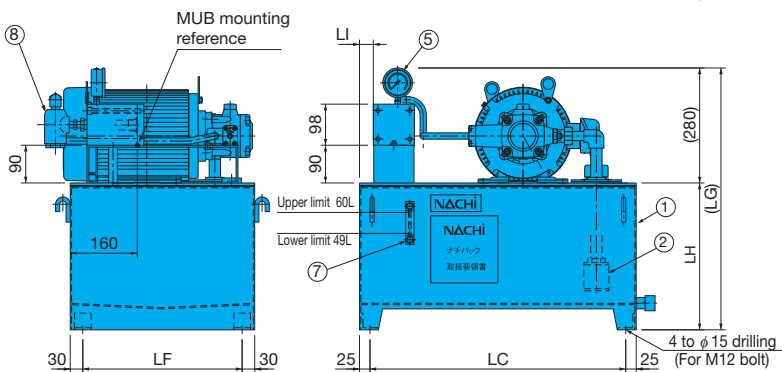
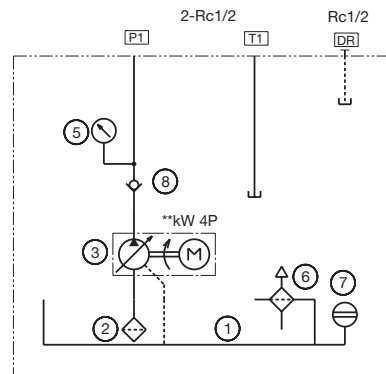
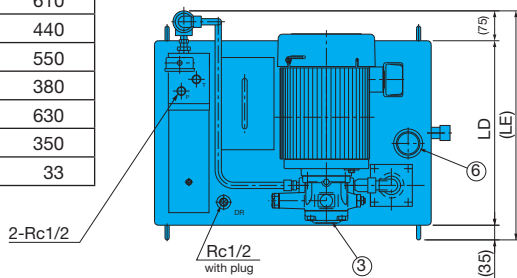

Part No.	Name	Model No.	Q'ty
1	Tank	**ℓ	1
2	Strainer	CS-06(150 mesh)	1
3	Uni-pump	UVD-1A-A*-**-4-40(60)	1
4			
5	Pressure gauge	GV50-173x**MPA	1
6	Fluid supply port/air breather	MSA-V30	1
7	Fluid level gauge	φ6x80L	1
8	Check valve	CA-T03-1-20	1

NCP-100-3.7VD1A3-C-22

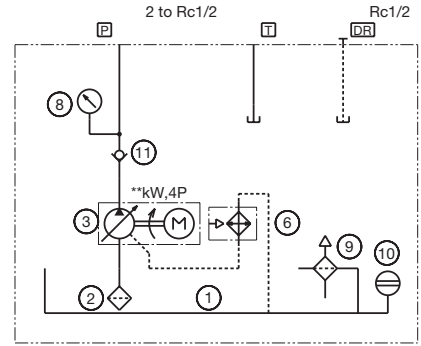
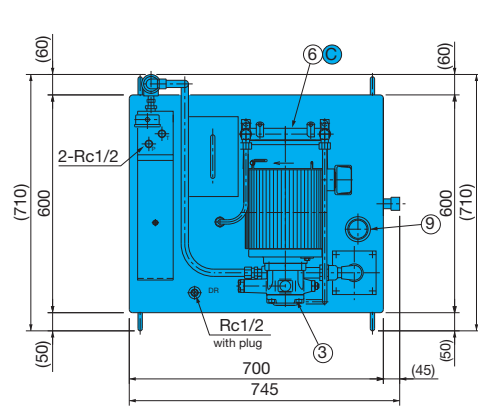

Part No.	Name	Model No.	Q'ty
1	Tank	100ℓ	1
2	Strainer	CS-08(150 mesh)	1
3	Uni-pump	UVD-1A-2A3-3.7-4-60	1
4			
5			
6	Radiator	3A92-001-1050	1
7			
8	Pressure gauge	GV50-173x**MPA	1
9	Fluid supply port/air breather	MSA-V30	1
10	Fluid level gauge	φ6x80L	1
11	Check valve	CA-T03-1-20	1

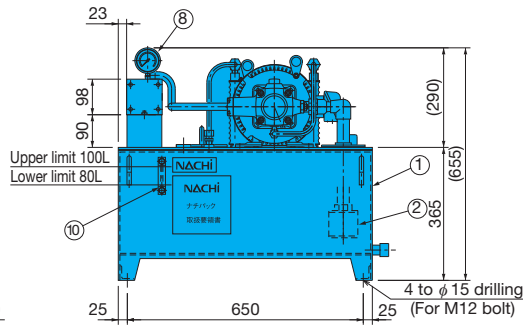
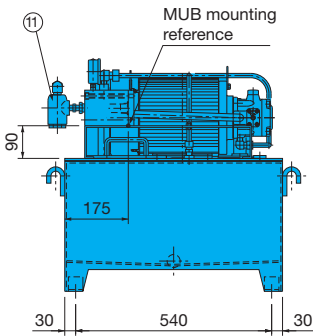

NCP-160-**VC2A*-*-13
NCP-250-**VC2A*-*-13

Symbol	Dimensions (mm)	
	160ℓ	250ℓ
LA	1120	1175
LB	850	1000
LC	780	930
LD	650	750
LE	750	850
LF	580	680
LG	415	495
LH	835	995
LI	385	420
LJ	420	500
LK	0	20
LL	100	215
LM	220	125
LN	75	0

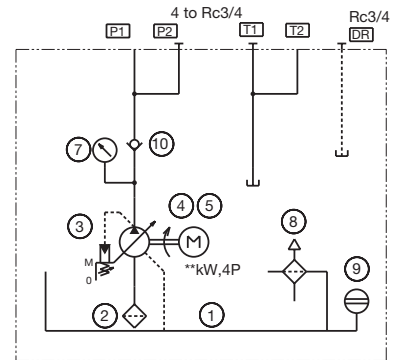
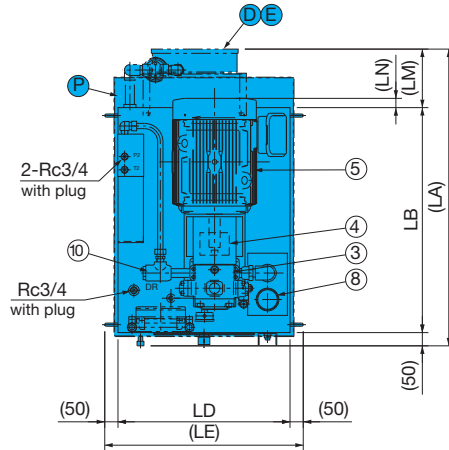

Part No.	Name	Model No.	Q'ty
1	Tank	**ℓ	1
2	Strainer	CS-10(150 mesh)	1
3	Pump	VDC-2A*A*-20	1
4	Coupling	CR-***J	1
5	Motor	Fully closed external fan Terminal B **kW-4P	1
6			
7	Pressure gauge	GV50-173x**MPA	1
8	Fluid supply port/air breather	MSA-V50-VS10	1
9	Fluid level gauge	φ8x120L	1
10	Check valve	CA-T06-1-20	1

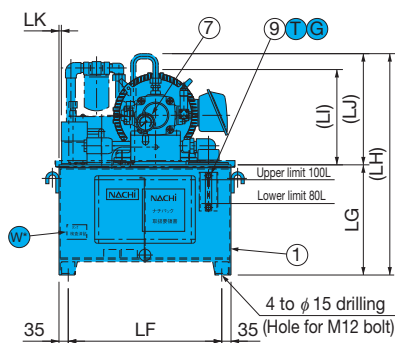
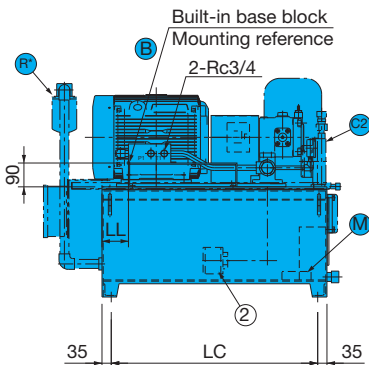

NCP-400-**VC3A*-*-13
 NCP-650-**VC3A*-*-13

Symbol	Dimensions (mm)	
	400ℓ	650ℓ
LA	1470	1790
LB	1200	1520
LC	1100	1420
LD	900	1010
LE	1014	1164
LF	800	910
LG	620	670
LH	1120	1170
LI	57	77
LJ	300	450

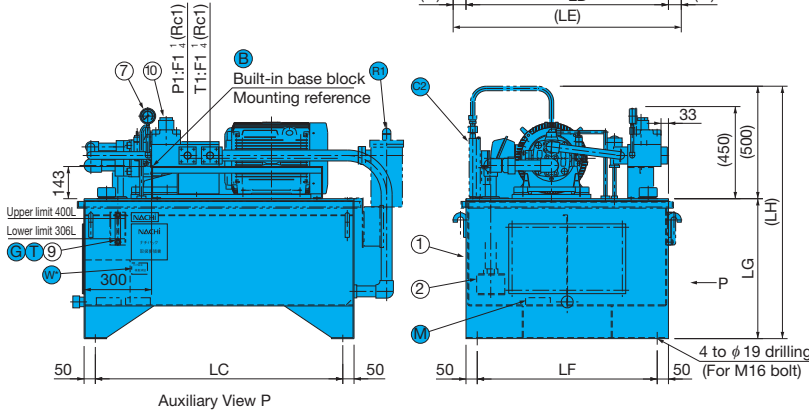
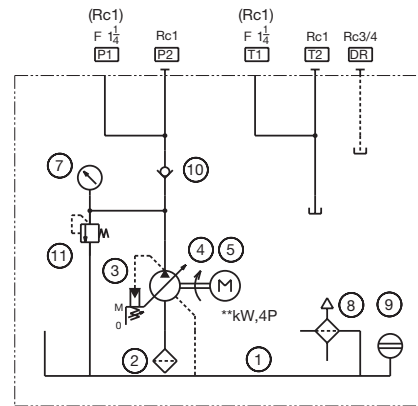
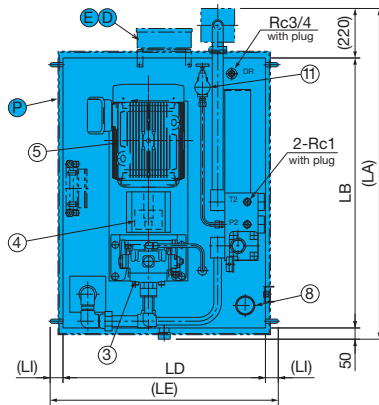

Part No.	Name	Model No.	Q'ty
1	Tank	**ℓ	1
2	Strainer	CS-12(150 mesh)	1
3	Pump	VDC-3A-1A*-20	1
4	Coupling	CR-***J	1
5	Motor	Fully closed external fan A terminal **kW-4P	1
6			
7	Pressure gauge	GV50-173**MPA	1
8	Fluid supply port/air breather	MSA-V50-VS10	1
9	Fluid level gauge	φ8×120L	1
10	Check valve	CA-G10-1-20	1
11	Relief valve	R-T03-3-12	1

● Variable Piston Pump Series
 NCP-40-**PV₁₆⁸N*-R-13

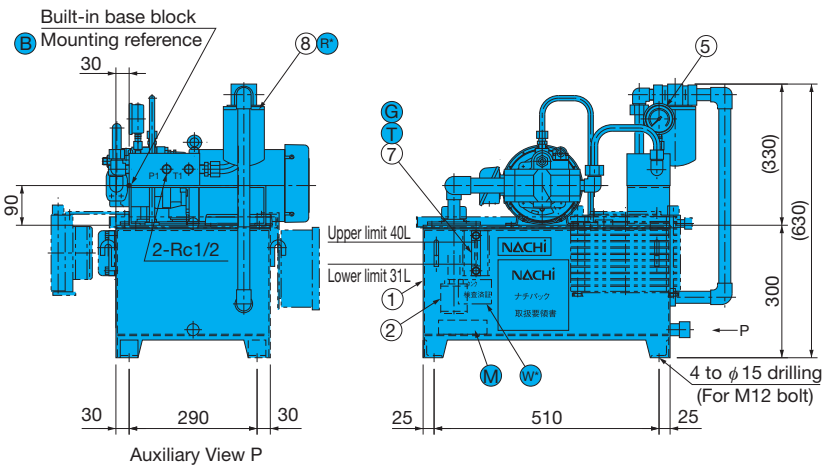
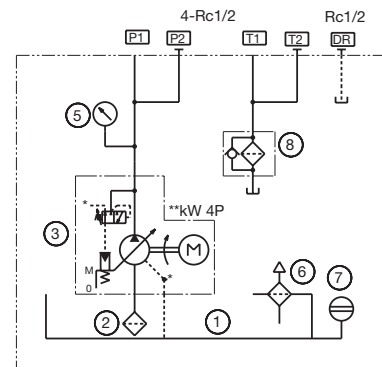
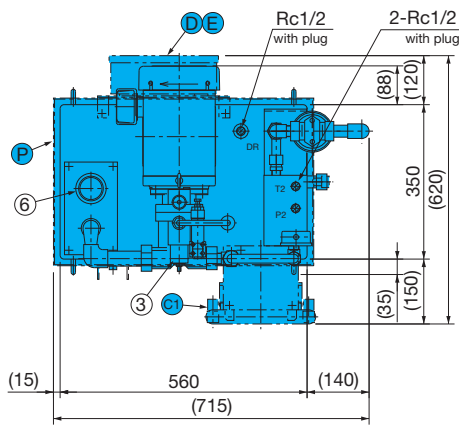

Part No.	Name	Model No.	Q'ty
1	Tank	40ℓ	1
2	Strainer	CS-06(150 mesh)	1
3	Uni-pump	UPV-A-**N*-**A-4-30(50)	1
4			
5	Pressure gauge	GV50-173**MPA	1
6	Fluid supply port/air breather	MSA-V30	1
7	Fluid level gauge	φ6×80L	1
8	Return filter	(FPL-06)CF-06 10μ paper	1

NCP-60-**PV16N*-R-13

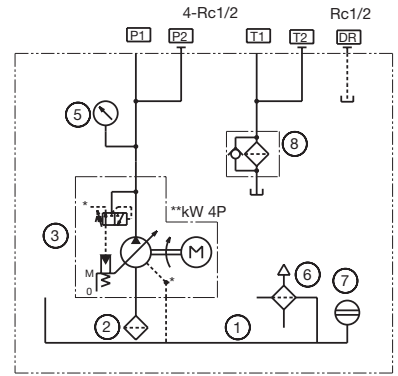
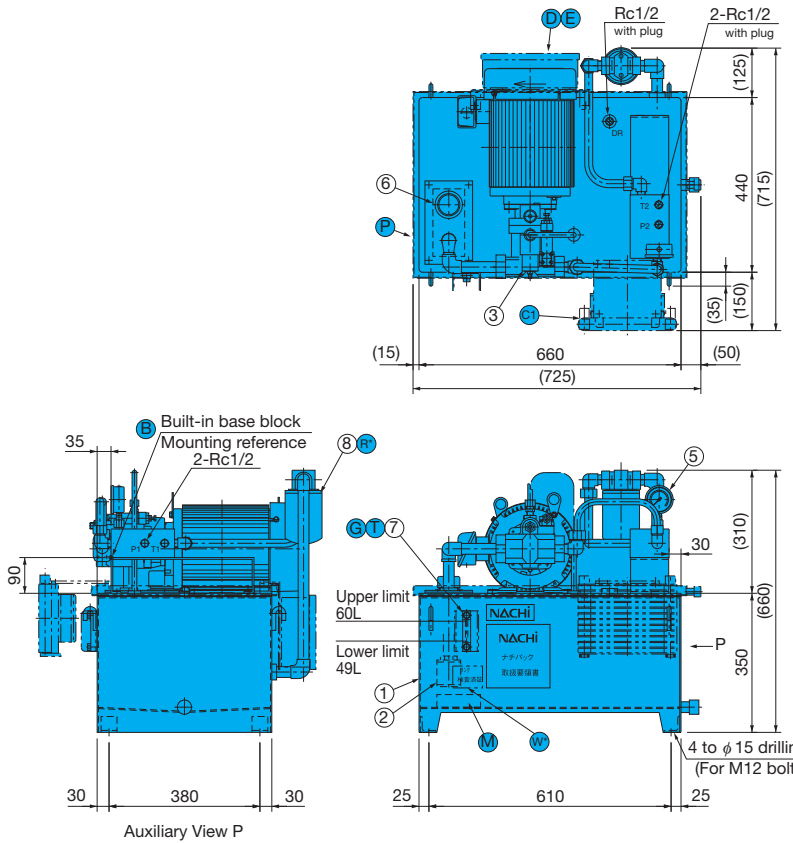

Part No.	Name	Model No.	Q'ty
1	Tank	60ℓ	1
2	Strainer	CS-06(150 mesh)	1
3	Uni-pump	UPV-1A-16N*-**A-4-30	1
4			
5	Pressure gauge	GV50-173x**MPA	1
6	Fluid supply port/air breather	MSA-V30	1
7	Fluid level gauge	φ6×80L	1
8	Return filter	(FPL-06)CF-06 10μ paper	1

NCP-60-**PV8N*-*-13

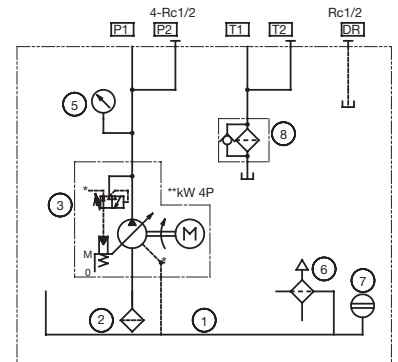
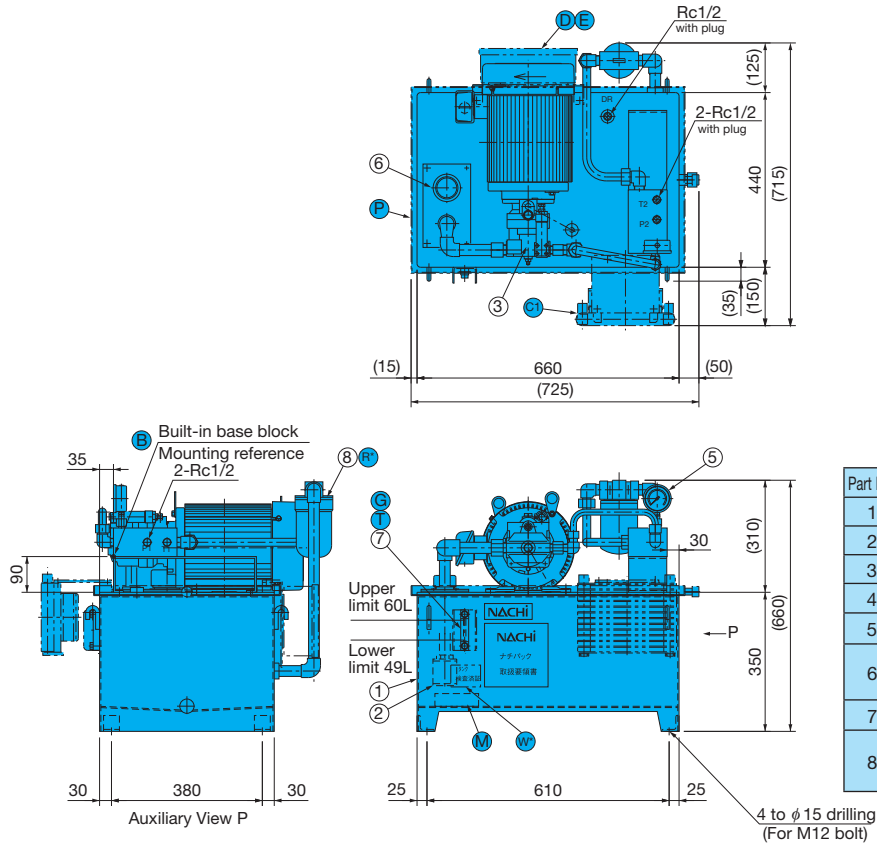

Part No.	Name	Model No.	Q'ty
1	Tank	**ℓ	1
2	Strainer	CS-06(150 mesh)	1
3	Uni-pump	UPV-0A-8N*-**A-4-50	1
4			
5	Pressure gauge	GV50-173x**MPA	1
6	Fluid supply port/air breather	MSA-V30	1
7	Fluid level gauge	φ6×80L	1
8	Return filter	(FPL-06)CF-06 10μ paper	1

NCP-100-****PV16N*-13**

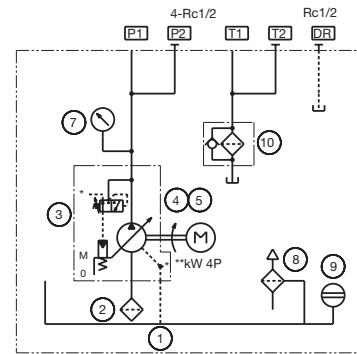
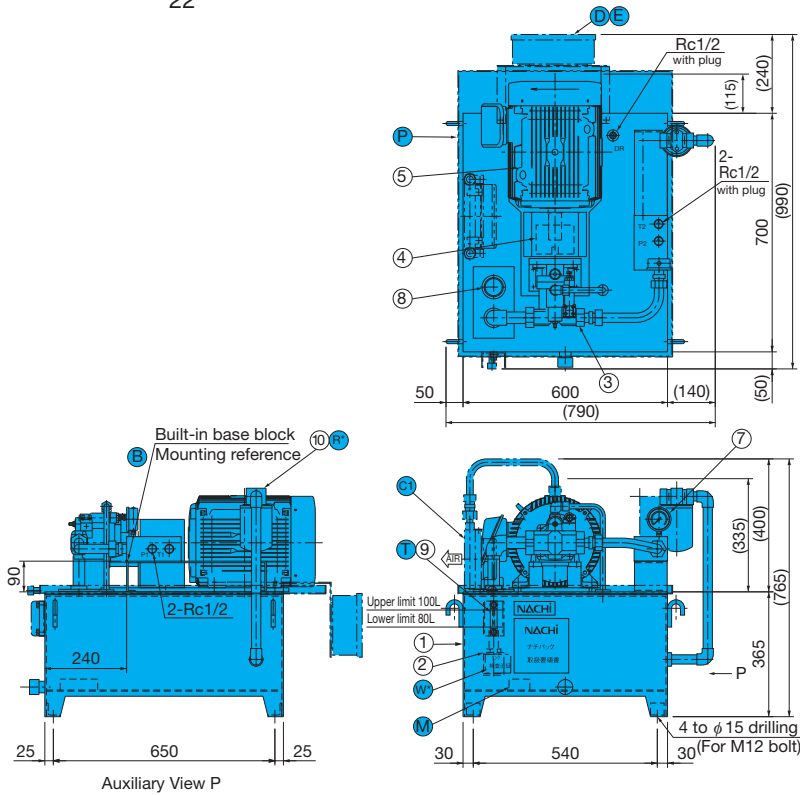

Part No.	Name	Model No.	Q'ty
1	Tank	100ℓ	1
2	Strainer	CS-06(150 mesh)	1
3	Pump	PVS-1A- **N*-12	1
4	Coupling	CR- ***J	1
5	Motor	Fully closed external fan A terminal **kW-4P	1
6			
7	Pressure gauge	GV50-173 **MPA	1
8	Fluid supply port/air breather	MSA-V30	1
9	Fluid level gauge	φ6×80L	1
10	Return filter	(FPL-06)CF-06 10μ paper	1

NCP-40-****PV16N*-(C1)R2-22**
NCP-60-****PV16N*-(C1)R2-22**

Symbol	Dimensions (mm)	
	40ℓ	60ℓ
LA	350	440
LB	560	660
LC	300	350
LD	620	710
LE	605	705
LF	630	665
LG	290	380
LH	510	610
LI	330	315
LJ	150	155
LK	0	30

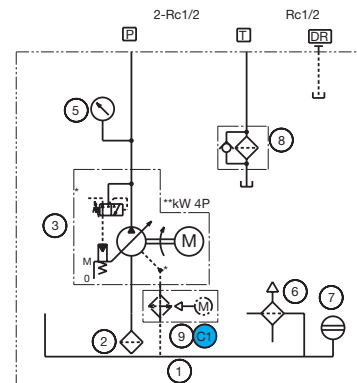
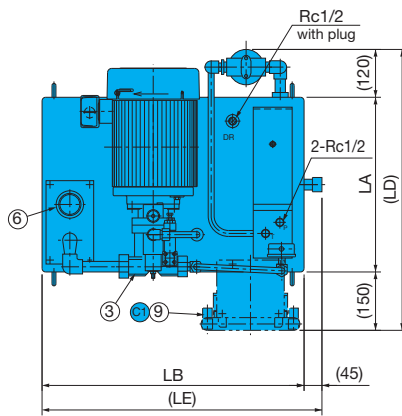

Part No.	Name	Model No.	Q'ty
1	Tank	**ℓ	1
2	Strainer	CS-06(150 mesh)	1
3	Uni-pump	UPV-1A-16N*- **A-4-30	1
4			
5	Pressure gauge	GV50-173 **MPA	1
6	Fluid supply port/air breather	MSA-V30	1
7	Fluid level gauge	φ6×80L	1
8	Return filter	FPL-06(10μ paper)	1
9	Fan cooler	3A92-001-0000	1

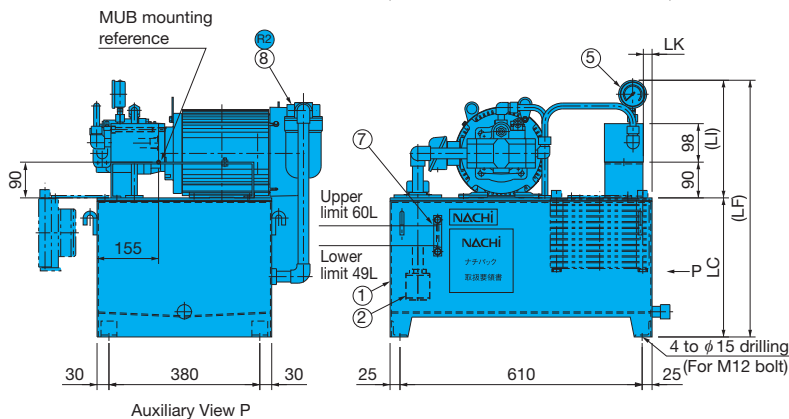

NCP-100-¹⁶PV₂₂N^{*}-(C1)R2-22

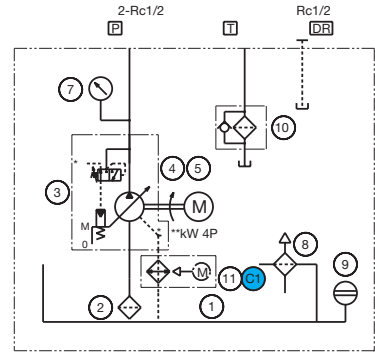
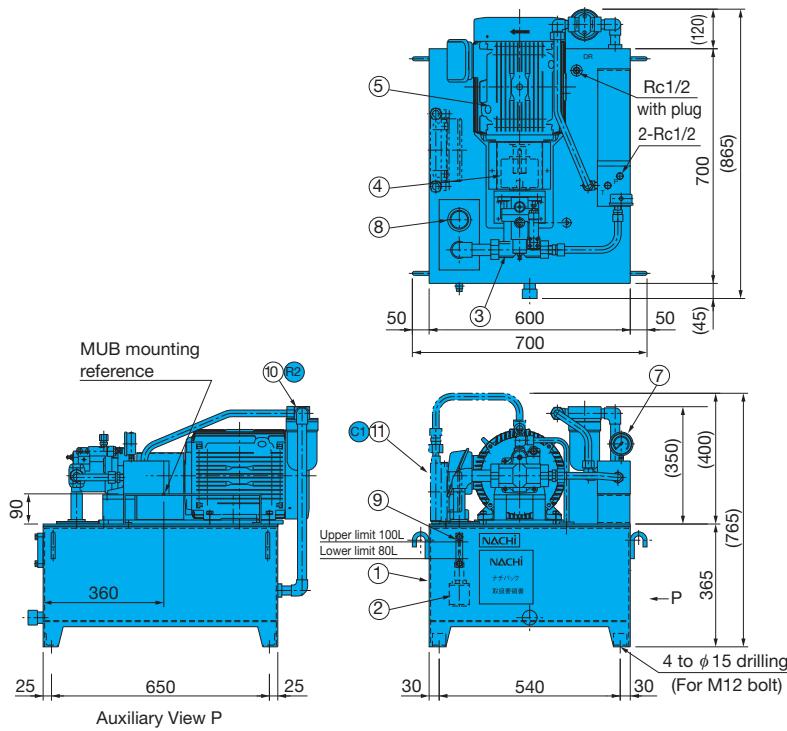

Part No.	Name	Model No.	Q'ty
1	Tank	100ℓ	1
2	Strainer	CS-06(150 mesh)	1
3	Pump	PVS-1A- ¹⁶ / ₂₂ N [*] -12	1
4	Coupling	CR-****J	1
5	Motor	Fully closed external fan A terminal *kW-4P	1
6			
7	Pressure gauge	GV50-173x**MPA	1
8	Fluid supply port/air breather	MSA-V30	1
9	Fluid level gauge	φ6x80L	1
10	Return filter	FPL-06(10μ paper)	1
11	Fan cooler	3A92-001-0000	1

NCP-160-¹⁶PV35N^{*}-R^{*}-13

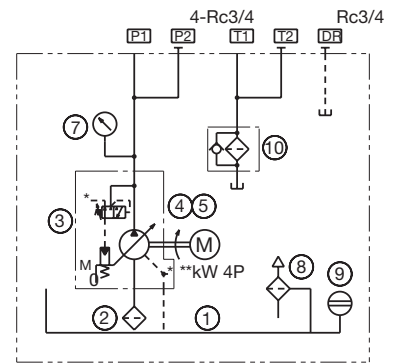
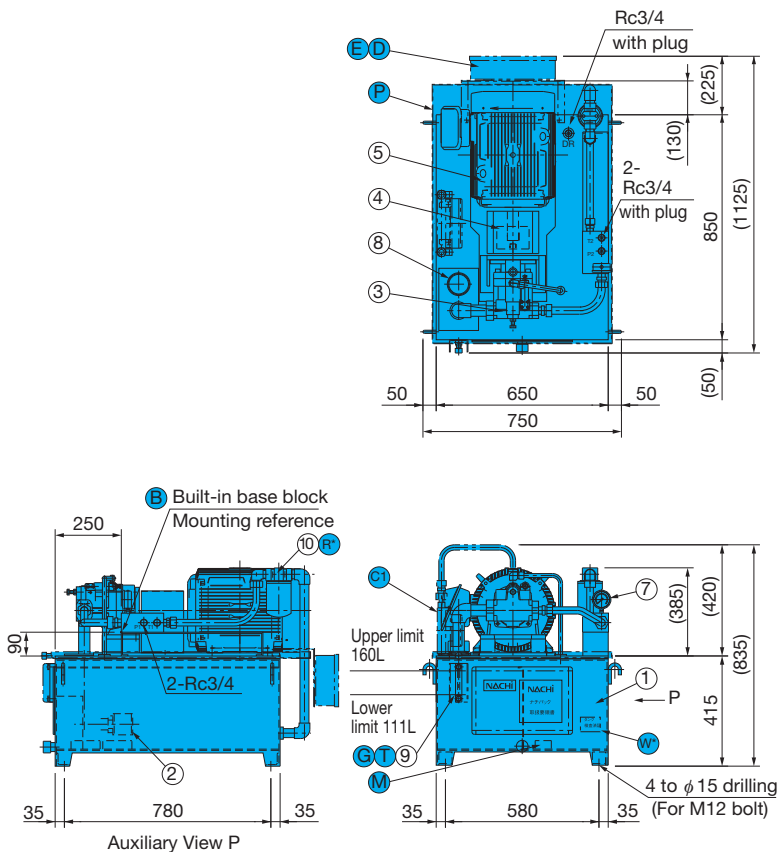

Part No.	Name	Model No.	Q'ty
1	Tank	160ℓ	1
2	Strainer	CS-10(150 mesh)	1
3	Pump	PVS-2A-35N [*] -12	1
4	Coupling	CR-****J	
5	Motor	Fully closed external fan A terminal *kW-4P	1
6			
7	Pressure gauge	GV50-173x**MPA	1
8	Fluid supply port/air breather	MSA-V50-VS10	1
9	Fluid level gauge	φ8x120L	1
10	Return filter	(FPL-08)CF-08 10μ paper	1

NCP-250-³⁵**PV₄₅N*-R*-13

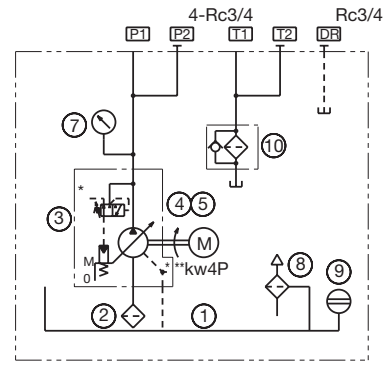
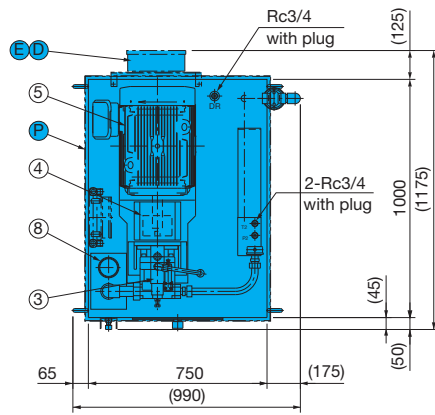

Part No.	Name	Model No.	Q'ty
1	Tank	250ℓ	1
2	Strainer	CS-10(150 mesh)	1
3	Pump	PVS-2A- ^{**} N*-12	1
4	Coupling	CR- ^{***} J	1
5	Motor	Fully closed external fan A terminal ^{**} kw-4P	1
6			
7	Pressure gauge	GV50-173 ^{**} MPA	1
8	Fluid supply port/air breather	MSA-V50-VS10	1
9	Fluid level gauge	φ8×120L	1
10	Return filter	FRS08-20P08T(20μ) (FPL-08)CF-08 10μ paper	1

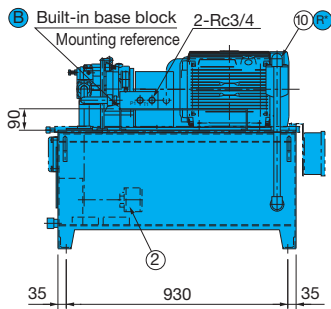

Auxiliary View P

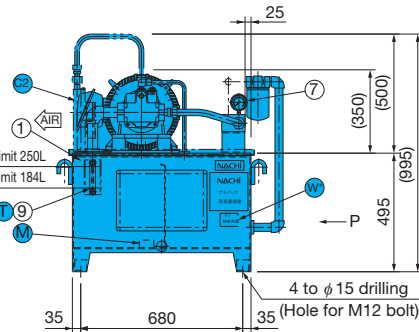

NCP-400-^{**}PV70N*-R1*-13
NCP-650-^{**}PV70N*-R1*-13

Symbol	Dimensions (mm)	
	400ℓ	650ℓ
LA	1470	1790
LB	1200	1520
LC	1100	1420
LD	900	1010
LE	1014	1164
LF	800	910
LG	620	670
LH	1180	1230
LI	57	77
LJ	300	450

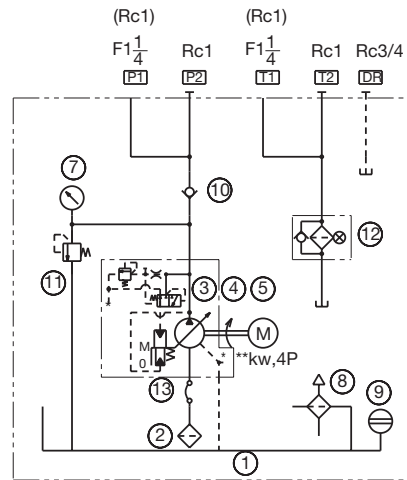
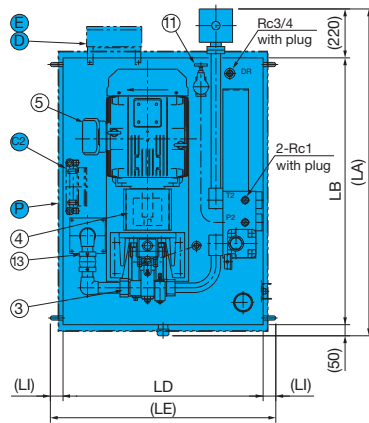

Part No.	Name	Model No.	Q'ty
1	Tank	^{**} ℓ	1
2	Strainer	CS-12(150 mesh)	1
3	Pump	PZS-3A-70N*-10	1
4	Coupling	CR- ^{***} J	1
5	Motor	Fully closed external fan A terminal ^{**} kw-4P	1
6			
7	Pressure gauge	GV50-173 ^{**} MPA	1
8	Fluid supply port/air breather	MSA-V50-VS10	1
9	Fluid level gauge	φ8×120L	1
10	Check valve	CA-G10-1-20	1
11	Relief valve	R-T03-3-12	1
12	Return filter	FRS12-20P-12F	1
13	Flexmaster joint	M1600-150-0350	1

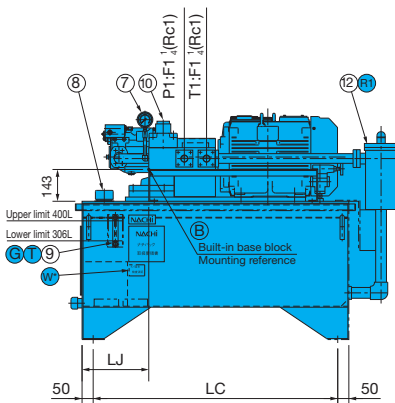

Auxiliary View P

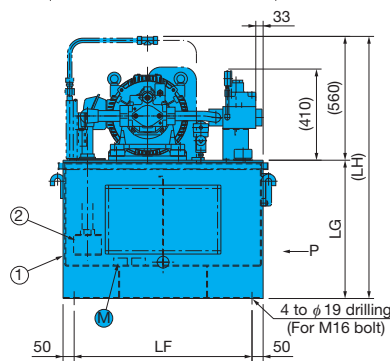

Note) Set (11) relief valve setting pressure so it is equivalent to pump setting pressure plus 1.0MPa {10.2kgf/cm²}.

Outlet Block Specifications

Design number 13
Outlet Block Dimensions

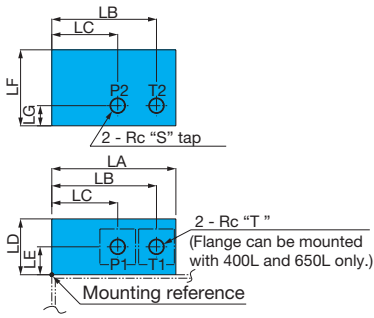

Design number 22
Outlet Block Dimensions

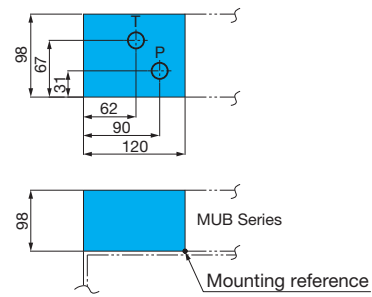

Tank Capacity	Dimensions (mm)							Outlet Size	
	LA	LB	LC	LD	LE	LF	LG	S	T
40L 60L 100L	160	135	85	72	36	98	26	1/2	1/2
160L 250L								3/4	3/4
400L 650L	300	260	160	98	49	148	48	1	JIS B 2291 SSA-32 (Rc)

Option B
MPU Series Built-in
(See base block specifications for dimensions.)

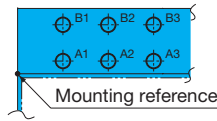

Oil Pan Specifications

A "headband type" oil pan is standard, and an oil pan drain is provided at one location (Rc3/8).

Structural Diagram

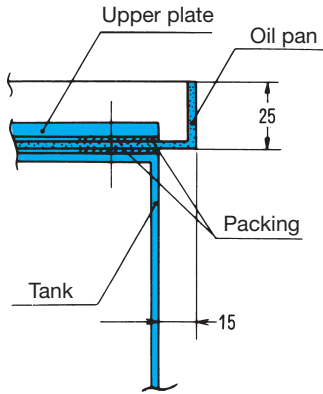

Forklift Mounting Leg Specifications

Forklift Mounting Leg Specifications

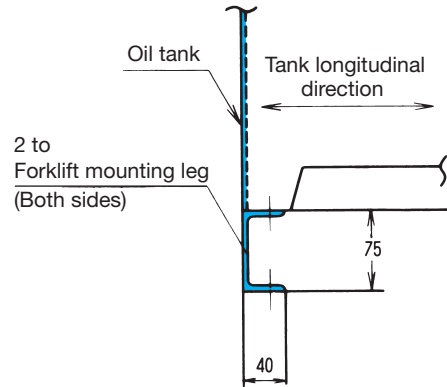

Standard Specifications

1. Paint Color: Mancel No. 5B6/3 (lacquer)

2. Motor Specifications:

		Wiring	Color Coding	Terminal number	Terminal	Terminal box specifications
Control System	SA SS	VCT-1.25mm ²	Single SOL White, Black Double SOL Red, White, Black, Green	1, 2, ... Consecutive numbers (Common: C)	Y Type Solderless	Inner : Mancel No. 2.5Y8/2 Dust-tight type, cover fastened by screws Outer : Mancel No 5B6/3 (Lacquer)
Drive System	to 3.7kW 5.5kW to	VCT IV + PF	Red, White, Black, Green Black (3) + Green	U, V, W, E	Round Solderless	
Fan cooler	3A92	VCT-1.25mm ²	White, Black	U2, V2	Round Solderless	

Base Block Specifications

Explanation of model No.

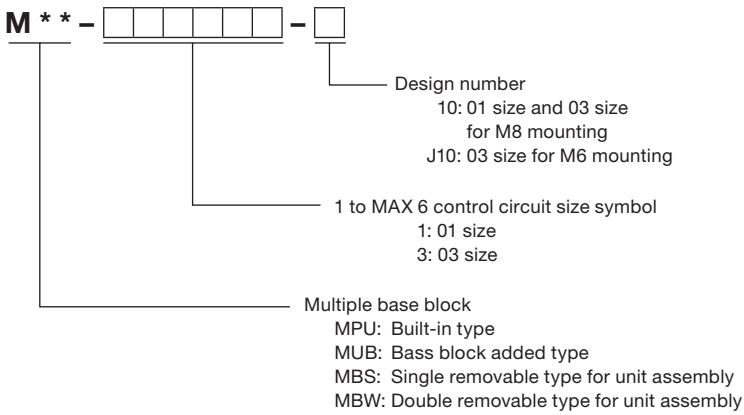

● MPU Series (Unit Built-in)

This base block is a special type built into the NCP Series.

Block Model Numbers, Appearance, Dimensions

01 size

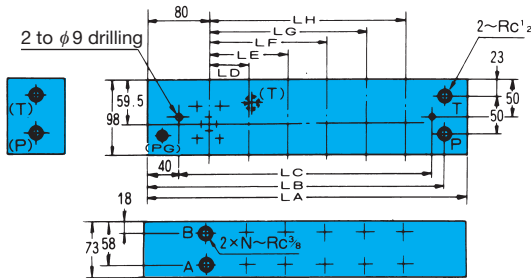

03 size

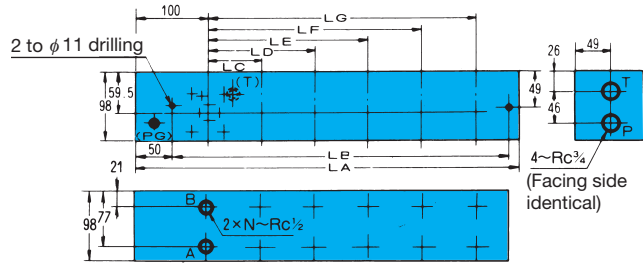

Model No.	Dimensions (mm)									Weight kg
	LA	LB	LC	LD	LE	LF	LG	LH	N	
MPU-1-10	160	130	75						1	8.3
-11-10	210	180	125	50					2	10.9
-111-10	260	230	175	50	100				3	13.4
-1111-10	310	280	225	50	100	150			4	16.0
-11111-10	360	330	275	50	100	150	200		5	18.6
-111111-10	410	380	325	50	100	150	200	250	6	21.2

Model No.	Dimensions (mm)									Weight kg
	LA	LB	LC	LD	LE	LF	LG	N		
MPU-3-J10(10)	160	95							1	11.1
-33-J10(10)	235	170	75						2	16.3
-333-J10(10)	310	245	75	150					3	21.5
-3333-J10(10)	385	320	75	150	225				4	26.7
-33333-J10(10)	460	395	75	150	225	300			5	31.9
-333333-J10(10)	535	470	75	150	225	300	375		6	37.0

- Note) 1. There are two types of mounting bolts available for the 03 size: M6 and M8. Be sure to specify the type of bolt you need.
 M6 : SA, SS-J Series
 M8 : SS Series
2. When using the 01/03 combination type
 a) The installation pitch uses the 03 size dimensions shown above, and for A and B ports only the 01 size installation part is Rc3/8.
 b) In the case of MPU-313131-J10, for example, valve installation locations 1, 3, and 5 counting from the left are 03 size, while 2, 4, 6 are 01 size.

Other

Space is limited in accordance with tank capacity, so use the basic data in the following table when designing the circuit.

	Tank Capacity	01 Space Block	03 Space Block
VD Series	40ℓ	Up to 4	Up to 3
	60ℓ	Up to 5	Up to 3
	100ℓ	Up to 6	Up to 5
	160ℓ	Up to 6	Up to 5
	250ℓ	Up to 6	Up to 6
	400, 650ℓ		Up to (2, 4, 6) + Up to (3, 2, 1)
PVS Series	30ℓ	Up to 3	
	60ℓ	Up to 4	Up to 3
		Z	Up to 3
	100ℓ	Up to 6	Up to 4
			Up to 6
	160, 250ℓ	Up to 6	Up to 4
	400, 650ℓ		Up to (2, 4, 6) + Up to (3, 2, 1)

Note) Note that using in series larger than those noted above causes overhang from the top plate.

●MUB Series (Base Block Additional Configurations)

This series makes it easy to add an option base block using only four mounting bolts. The following shows the range of the possible addition. In this configuration, the NCP unit design number becomes 22.

Block Model Numbers, Appearance, Dimensions

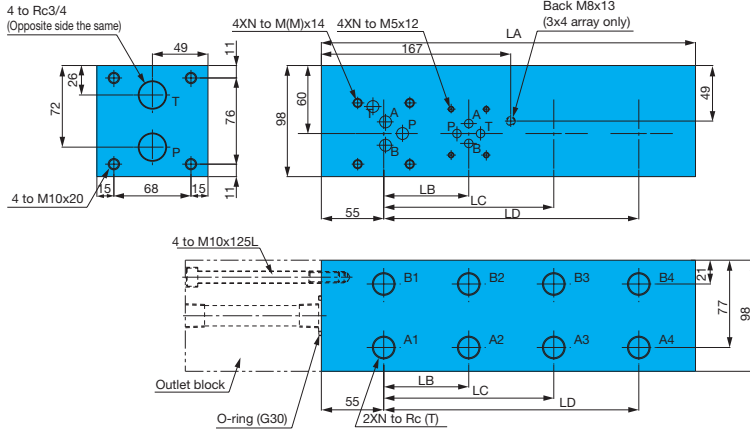

Model No.	Dimensions (mm)							Weight kg
	LA	LB	LC	LD	N	M	T	
MUB-1-10	105				1	—	3/8	7.6
MUB-3-J10(10)	105				1	6(8)	1/2	7.6
MUB-11-10	180	75			2	—	3/8	12.8
MUB-33-J10(10)	180	75			2	6(8)	1/2	12.8
MUB-111-10	255	75	150		3	—	3/8	18.0
MUB-333-J10(10)	255	75	150		3	6(8)	1/2	18.0
MUB-1111-10	330	75	150	225	4	—	3/8	23.2
MUB-3333-J10(10)	330	75	150	225	4	6(8)	1/2	23.2

22 Design Series Scope

This series consists of a total of six best-seller piston and vane types with 40, 60, and 100ℓ tanks. Note that piston Z type and vane VC type are not included.

- Note) 1. There are two types of mounting bolts available for the 03 size: M6 and M8. Be sure to specify the type of bolt you need.
M6 : SA, SS-J Series
M8 : SS Series
2. When using the 01/03 combination type
a)The installation pitch uses the 03 size dimensions shown above, and for A and B ports only the 01 size installation part is Rc3/8.
b)In the case of MUB-3131-J10, for example, valve installation locations 1 and 3 counting from the left are 03 size, while 2, 4 are 01 size.
3. When using a 2-speed plate, a special MUB type is used. Contact your agent for more information.

Option Base Block Addition Scope

Tank Capacity	01 Base Block	03 Base Block
40ℓ	Up to 2	Up to 2
60ℓ	Up to 3	Up to 3
100ℓ	Up to 4	Up to 4

Option Base Block Installation Procedure

Loosen bolts ① and ④ and remove plate ②. Next, after checking to ensure that O-ring ③ is installed, install the option base block using ①, ④, and ⑤.

- Note) ④ and ⑤ are used only in 3 and 4 multi configurations.
In single and double configurations, ④ and ⑤ are just removed.

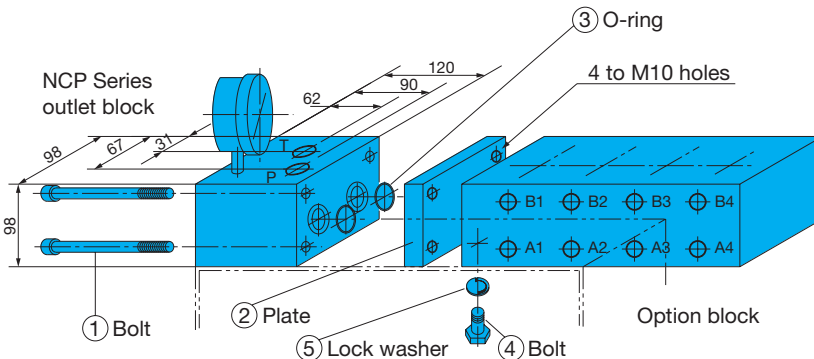
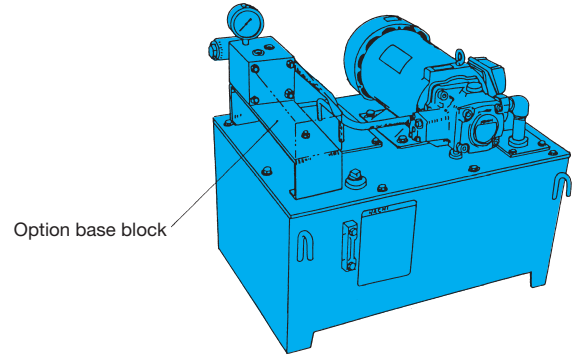

Part No.	Name	Model No.
1	Hexagon Socket Head Bolt	M10 x 125
2	Plate	98 x 98 x 15t
3	O-ring	1B-G30
4	Hex bolt	M8 x 25
5	Lock washer	For M8

●MBS, MBW Series (Unit Assembly Type)

This base block is used to install the valve unit only around machinery.

Block Model Numbers, Appearance, Dimensions

MBS Series (Single Ejection Multi Block)

01 size

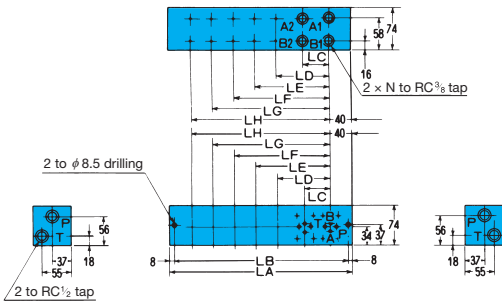

MBW Series (Double Ejection Multi Block)

01 size

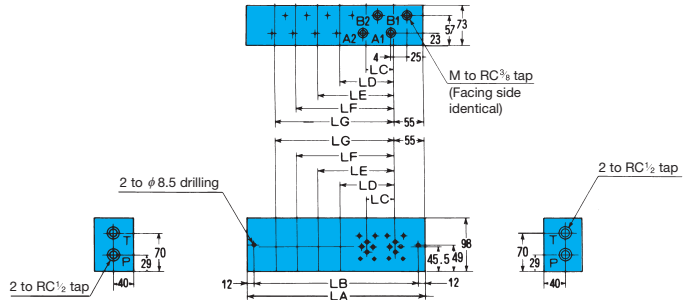

Model No.	Dimensions (mm)								Weight kg	
	LA	LB	LC	LD	LE	LF	LG	N		
MBS -1-10	80	64						1	3.4	
-11-10	130	114	50					2	5.5	
-111-10	180	164	50	100				3	7.6	
-1111-10	230	214	50	100	150			4	9.8	
-11111-10	280	264	50	100	150	200		5	11.9	
-111111-10	330	314	50	100	150	200	250	6	14	
-1111111-10	380	364	50	100	150	200	250	300	7	16

Model No.	Dimensions (mm)								Weight kg	
	LA	LB	LC	LD	LE	LF	LG	M		
MBW -1-10	110	86						2x2	1	5.7
-11-10	160	136	50					4x2	2	8.3
-111-10	210	186	50	100				6x2	3	10.9
-1111-10	260	236	50	100	150			8x2	4	13.4
-11111-10	310	286	50	100	150	200		10x2	5	16
-111111-10	360	336	50	100	150	200	250	12x2	6	18.6

03 Size (01, 03 Connection Type)

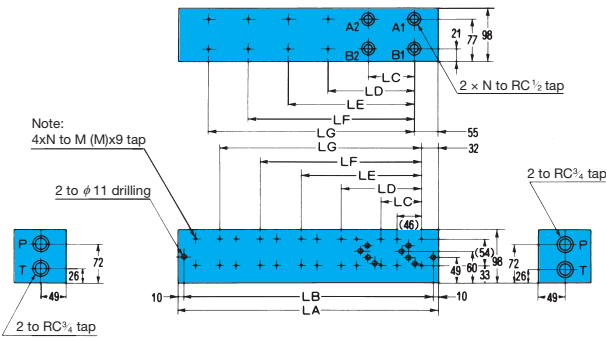

Model No.	Dimensions (mm)								Weight kg	
	LA	LB	LC	LD	LE	LF	LG	M ^{Note 1)}		
MBS-3 ~J10(10)	110	90						6(8)	1	8.2
-**~J10(10)	185	165	75					6(8)	2	13.8
-***~J10(10)	260	240	75	150				6(8)	3	19.4
-****~J10(10)	335	315	75	150	225			6(8)	4	25.0
-*****~J10(10)	410	390	75	150	225	300		6(8)	5	30.7
-*****~J10(10)	485	465	75	150	225	300	375	6(8)	6	36.3

- Note) 1. There are two types of mounting bolts available for the 03 size: M6 and M8. Be sure to specify the type of bolt you need.
M6 : SA, SS-J Series
M8 : SS Series
2. When using the 01/03 combination type
a)The installation pitch uses the 03 size dimensions shown above, and for A and B ports only the 01 size installation part is Rc3/8.
b)In the case of MBS-313131-J10, for example, valve installation locations 1, 3, 5 counting from the right are 03 size, while 2, 4, 6 are 01 size.

03 Size (01, 03 Connection Type)

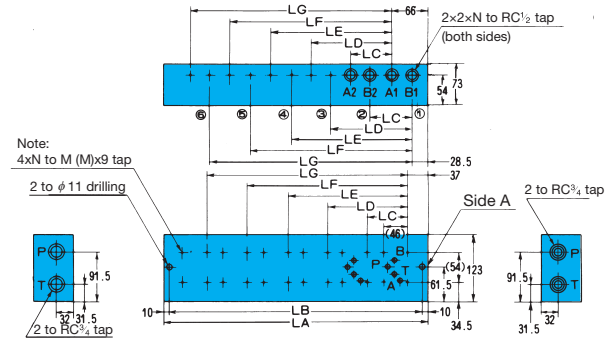

Model No.	Dimensions (mm)								Weight kg	
	LA	LB	LC	LD	LE	LF	LG	M ^{Note 1)}		
MBW-3 ~J10(10)	120	100						6(8)	1	8.4
-**~J10(10)	195	175	75					6(8)	2	13.6
-***~J10(10)	270	250	75	150				6(8)	3	18.9
-****~J10(10)	345	325	75	150	225			6(8)	4	24.1
-*****~J10(10)	420	400	75	150	225	300		6(8)	5	29.4
-*****~J10(10)	495	475	75	150	225	300	375	6(8)	6	34.6

- Note) 1. There are two types of mounting bolts available for the 03 size: M6 and M8. Be sure to specify the type of bolt you need.
M6 : SA, SS-J Series
M8 : SS Series
2. When using the 01/03 combination type
a)The installation pitch uses the 03 size dimensions shown above, and for A and B ports only the 01 size installation part is Rc3/8.
b)In the case of MBS-313131-J10, for example, valve installation locations 1, 3, and 5 counting from the right are 03 size, while 2, 4, 6 are 01 size.

Control Circuit Option Specifications

Option G (Pressure Gauge Panel Dimension Diagram)

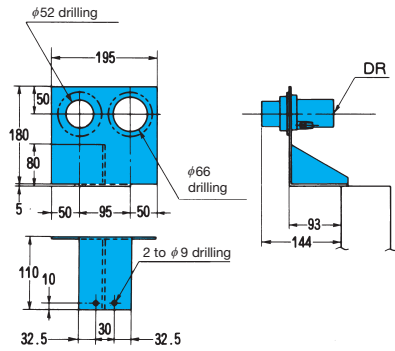

Option N (Nameplate Panel Dimension Diagram)

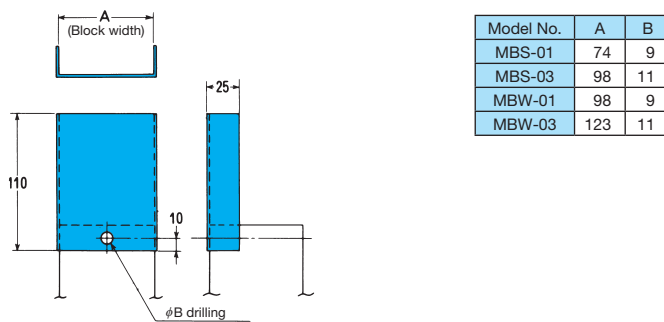

Note) The nameplate panel is separate from the base block when shipped, so fasten them together during installation.

Option P (Oil Pan Dimension Diagram)

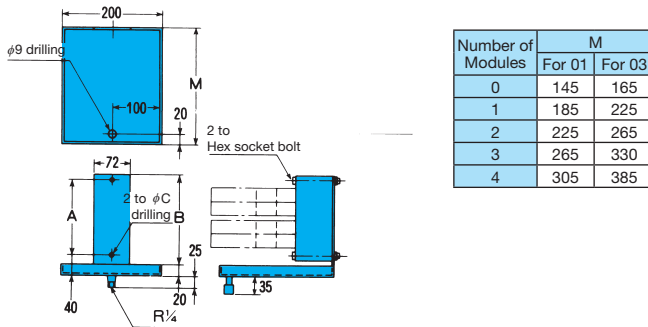

Note) When shipped, the oil pan is fastened from the back by the same nut as the block.

Option P Dimension Table

Model No.	A	B	C	Applicable
P-S1-1	64	92	9	MBS-1
-2	114	142	9	11
-3	164	192	9	111
-4	214	242	9	1111
-5	264	292	9	11111
-6	314	342	9	111111
-7	364	392	9	1111111

Model No.	A	B	C	Applicable
P-W1-1	86	118	9	MBW-1
-2	136	168	9	11
-3	186	218	9	111
-4	236	268	9	1111
-5	286	318	9	11111
-6	336	368	9	111111

Model No.	A	B	C	Applicable
P-S3-1	90	120	11	MBS-3
-2	165	195	11	33
-3	240	270	11	333
-4	315	345	11	3333
-5	390	420	11	33333
-6	465	495	11	333333

Model No.	A	B	C	Applicable
P-W3-1	100	130	11	MBW-3
-2	175	205	11	33
-3	250	280	11	333
-4	325	335	11	3333
-5	400	430	11	33333
-6	475	505	11	333333