



NNP Series (Low-noise Standard Variable Pump Unit)

Features

Newly developed compact variable pump unit has environmentally friendly low hydraulic oil temperature for cutting and manufacturing equipment hydraulic units. Extensive lineup in the series to handle requirements exactly.

Low hydraulic oil temperature = room temperature + 7°C

NNP-20-22P16 N1-21
60Hz, 7MPa Full cut-off in continuous operation

Fan to cool pump drain is standard equipment, hydraulic oil temperature are kept low using tank construction focused on anti-foaming.

A wide selection of models from which to choose

Basic Series: 10 types
Pump Variable Controllers: 5 types
Options: 8 types

A wide range of models provides a selection of capacity levels, and selecting a variable control mechanism helps to reduce energy needs.

Specifications

Power supply: AC200V-50/60Hz AC220V-60Hz

Model No.	Pump Capacity cm ³ /rev	Motor capacity kW-P	Maximum Pressure {Full Cutoff Pressure} MPa(kgf/cm ²)	Tank Capacity ℓ	Fan Cooler Motor Input W{at50/60Hz}	Standard Weight kg	
NNP-20-22P8N*-**-21	8.0	2.2-4	21{214}	20	16/15W Single-phase	80 ^{Note)}	
NNP-20-37P8N*-**-21		3.7-4		20		88 ^{Note)}	
NNP-20-22P16N*-**-21	16.5	2.2-4		20		85 ^{Note)}	
NNP-30-37P16N*-**-21		3.7-4		30		93 ^{Note)}	
NNP-20-22P22N*-**-21	22.0	2.2-4		14{143}		20	85 ^{Note)}
NNP-30-37P22N*-**-21		3.7-4				30	93 ^{Note)}
NNP-40-37P35N*-**-21	35.0	3.7-4	21{214}	40	35/33W Single-phase	115 ^{Note)}	
NNP-60-55P35N*-**-21		5.5-4		60		135 ^{Note)}	
NNP-80-37P45N*-**-21	45.0	3.7-4	14{143}	80		133 ^{Note)}	
NNP-80-55P45N*-**-21		5.5-4		80		140 ^{Note)}	

Note) Operating fluid is not included in options

Explanation of model No.

NNP - 20 - 22 P 16 N2 - ** - 21

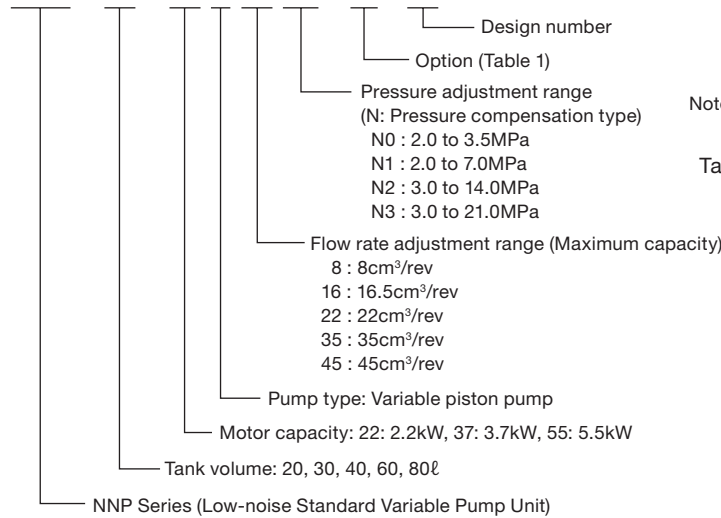

Note) N3 is not available for flow rate adjustment ranges 22 and 45.

Table 1: Option Symbols (Specify in alphabetic sequence.)

Symbol	Description
F*	F*Type block (See block specifications.)
R*	R*Type block (See block specifications.)
G	Fluid level gauge guard
H	Temperature switch (Contact on at oil temperature of 65°C)
M	Microseparator
P	Bottom oil pan
S	Float switch (Contact on at fluid low limit level)
T	Fluid level gauge with temperature gauge (with guard)
W	Self Leak Test

Note) Return filter and fan cooler are equipped as standard.

Selecting a Motor

The lower sides of the curves for each of the motors shown in the graph indicate the operating range under rated output for that motor.

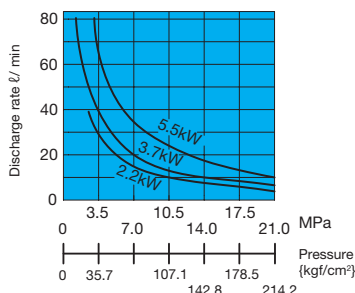

Tank Capacity and Motor/Pump Combinations

Tank Capacity (ℓ)	Motor capacity (kW-P)			2.2 - 4					3.7 - 4		5.5 - 4		
	Pump Capacity (cm ³ /rev)			8	16	22	8	16	22	35	45	35	45
20ℓ	○	○	○	○									
30ℓ					○	○							
40ℓ									○				
60ℓ												○	
80ℓ												○	○

Design Drawings, Dimension Tables

Model No.	Dimensions																								
	LA	LB	LC	LD	LE	LF	LG	LH	LI	LJ	LK	LL	LM	LN	LO	LP	LQ	LR	KD	H	L	P	T	R	
NNP-20-22P 8N***-21														231								1/2			
NNP-20-22P16N***-21	575		506		66	240	266							235		—	350				20L	16L	3/4		
NNP-20-22P22N***-21		350		505				340	450	290	426	400	600	233	80			189			φ27		1/2	3/4	3/8
NNP-30-37P 8N***-21																									
NNP-30-37P16N***-21	625				116									247		21	371				30L	26	3/4		
NNP-30-37P22N***-21																									
NNP-40-37P35N***-21			560			267								248		17	467				40L	30			
NNP-60-55P35N***-21			697			358	339							268		19	469				φ33	60L	50L		
NNP-80-37P45N***-21	743	450		620	119			440	560	390	536	500	770	248		17	467				φ27	80L	70L	1-1/4	1/2
NNP-80-55P45N***-21			793			454	339							268		19	467				φ33				

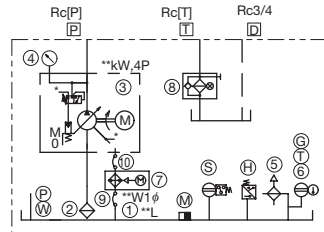
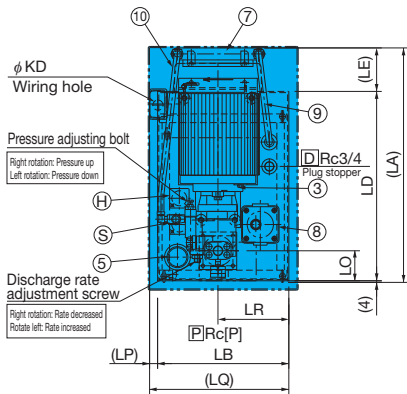

Part No.	Part Name
1	Fluid tank
2	Suction strainer
3	Uni-pump
4	Pressure gauge
5	Fluid supply port/air breather
6	Fluid level gauge
7	Fan cooler
8	Return filter
9	Flexible hose
10	Flexible hose

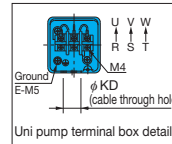
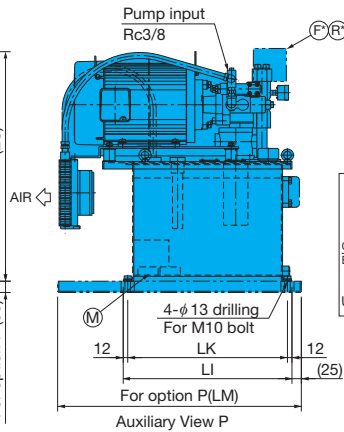
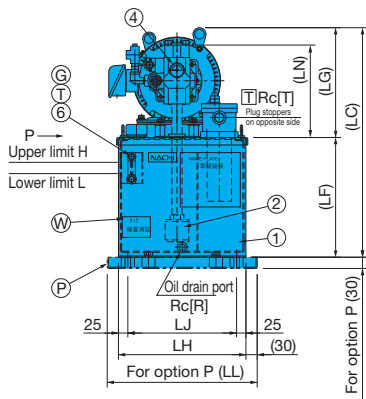

Part No.	Part Name
F*	Built-in block (F Type)
R*	Built-in block (R Type)
G	Fluid level gauge with guard
H	Temperature switch
M	Microseparator
P	Bottom oil pan
S	Float switch
T	Fluid level gauge with temperature gauge (with guard)
W	Self leak test

Option Installation Example

Model No. : NNP-20-22P16N2-F3HMPSTW-21

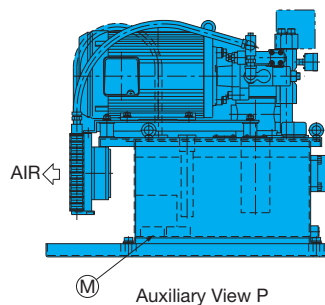
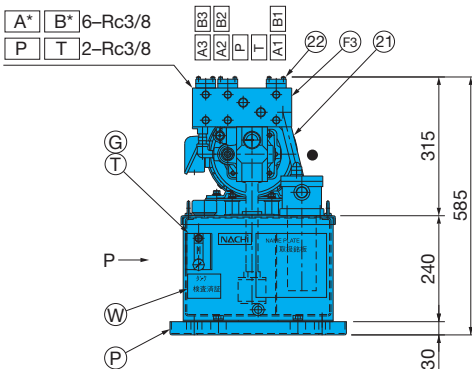
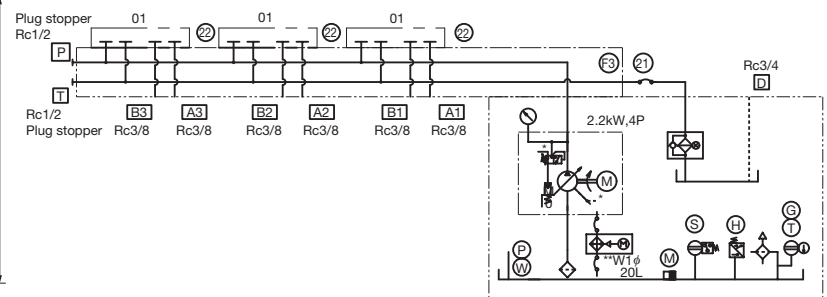
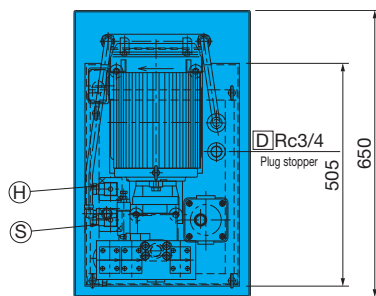

Symbol	Name
21	Flexible hose
22	End Plates

Note) Part numbers 21 and 22 are standard with a built-in block.

F* and R* Block Specifications

Note) Note that there are certain restrictions on block-equipped combinations. See the Selection Precautions on page L-32.

Options F1, F2, F3, F6

Symbol	Description	Model No.	
		Tank Capacity 20, 30ℓ	Tank Capacity 40, 60, 80ℓ
F1	F1 Type Block (01 x 1)	F1-1A	F1-2A
F2	F2 Type Block (01 x 2)	F2-1A	F2-2A
F3	F3 Type Block (01 x 3)	F3-1A	F3-2A
F6	F6 Type Block (03 x 1 - M6)	F6-1A-M6 (Standard M6)	F6-2A-M6 (Standard M6)

Tank Capacity	Options	Dimensions																
		MA	MB	MC	MD	ME	MF	MG	MH	MI	MJ	MK	ML	MM	MN	N	F	S
20ℓ 30ℓ	F1	133	—	—	—	—	—	—	—	—	—	—	—	—	—	2	—	—
	F2	175	—	55	20	90	55	88	15	58	33	22	88	65	21	4	3/8	1/2
	F3	225	105	—	—	—	—	—	—	—	—	—	—	—	—	6	—	—
	F6	152	—	—	25	102	67	103	18	67	39	25	103	80	26	2	1/2	3/4
40ℓ 60ℓ 80ℓ	F1	143	—	—	—	—	—	—	—	—	—	—	—	—	2	—	—	
	F2	183	—	58	20	96	58	88	15	58	33	22	98	68	24	4	3/8	1/2
	F3	233	108	—	—	—	—	—	—	—	—	—	—	—	—	6	—	—
	F6	155	—	—	25	105	70	103	18	67	39	25	103	73	—	2	1/2	3/4

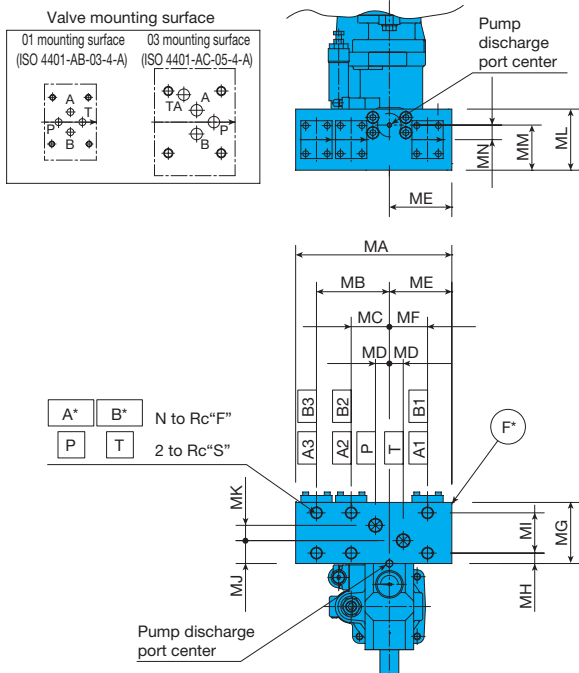

Options R1, R2, R3, R6

Symbol	Description	Model No.	
		Tank Capacity 20, 30ℓ	Tank Capacity 40, 60, 80ℓ
R1	R1 Type Block (01 x 1)	R1-1A	R1-2A
R2	R2 Type Block (01 x 2)	R2-1A	R2-2A
R3	R3 Type Block (01 x 3)	R3-1A	R3-2A
R6	R6 Type Block (03 x 1 - M6)	R6-1A-M6 (Standard M6)	R6-2A-M6 (Standard M6)

Tank Capacity	Options	Dimensions																	
		MA	MB	MC	MD	ME	MF	MG	MH	MI	MJ	MK	ML	MM	MN	MO	N	F	S
20ℓ 30ℓ	R1	123	—	—	—	—	—	—	—	—	—	—	—	—	—	2	—	—	
	R2	170	—	42	42	85	12	73	15	43	20	17	98	42	16.5	38	4	3/8	1/2
	R3	220	92	—	—	—	—	—	—	—	—	—	—	—	—	6	—	—	
	R6	160	—	—	54	119	0	98	18	62	49	0	108	47	9	—	2	1/2	3/4
40ℓ 60ℓ 80ℓ	R1	132	—	—	—	—	—	—	—	—	—	—	—	—	2	—	—		
	R2	180	—	45	45	92	13	73	15	43	23	14	103	45	16.5	40	4	3/8	1/2
	R3	230	95	—	—	—	—	—	—	—	—	—	—	—	—	6	—	—	
	R6	167	—	—	57	122	0	98	18	62	49	0	110	47	9	—	2	1/2	3/4

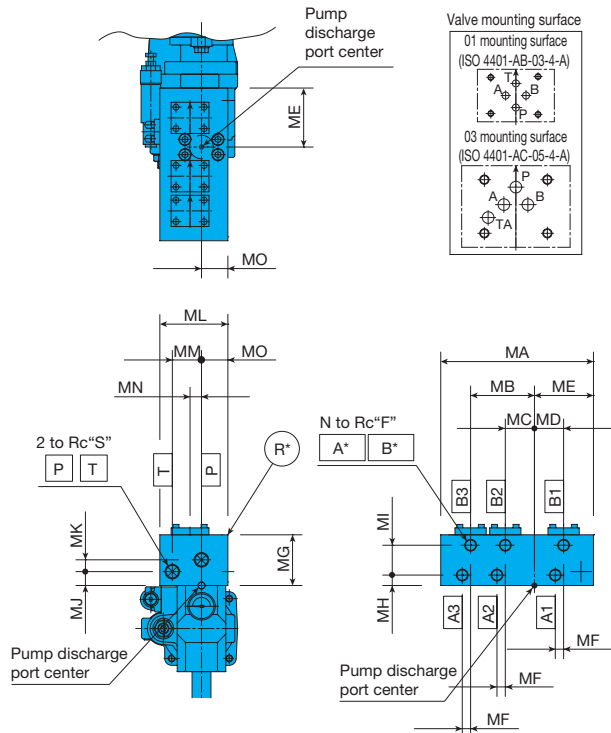

Note) Each block is shipped with plug stoppers in the P and T ports.

Hydraulic Circuit Diagram

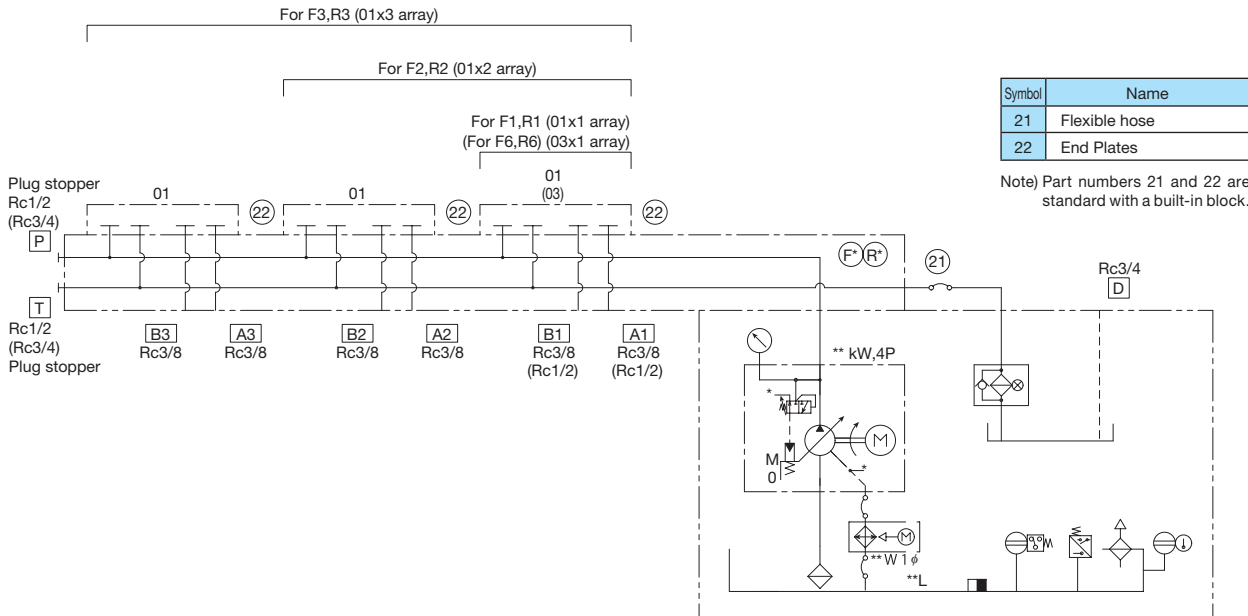

Typical Performance Characteristics

Oil Temperature Rise Characteristics - Full Cutoff

These graphs show oil temperature rise during continuous operation.

- Tank Fluid Pressure = Room Temperature + Oil Temperature Rise Value
- Operating Fluid: ISO VG32 equivalent
- Revolution Speed: 1800min⁻¹ (60Hz)

Note) The oil temperature rise value depends on actual operating conditions, and so actual temperatures may be different from those indicated above.

NNP-20-22P16N*-21

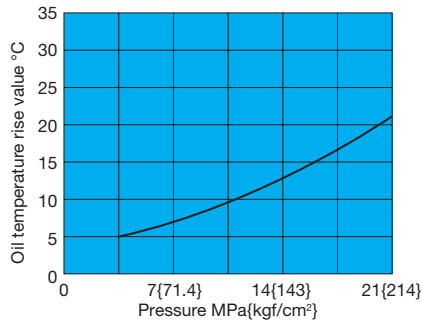

NNP-30-37P22N*-21

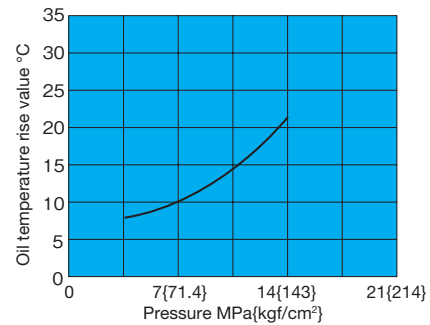

NNP-60-55P35N*-21

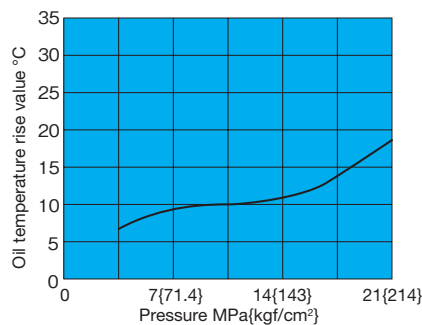

Noise Characteristics - Measurement Position

These graphs show noise values at locations one meter in front of and behind the pump.

- ISO VG32 equivalent
- Oil Temperature: 40±5°C

Note) Noise characteristics are affected by the condition of the floor and stand where the unit is mounted, whether there are noise reflective items nearby, and other factors. Such factors can produce different characteristics than those indicated below.

— Full cutoff

NNP-20-22P16N*-21

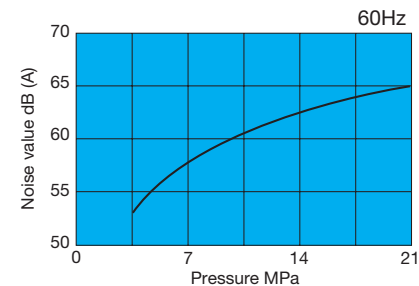
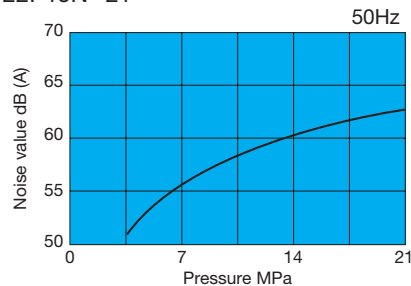

NNP-30-37P22N*-21

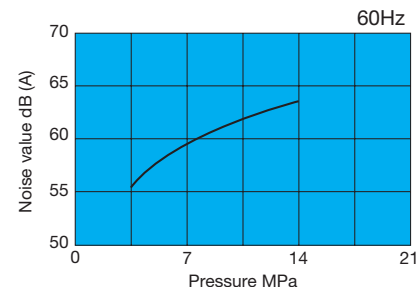
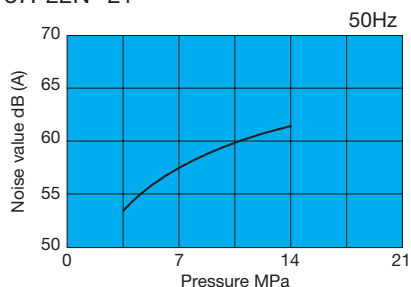

NNP-60-55P35N*-21

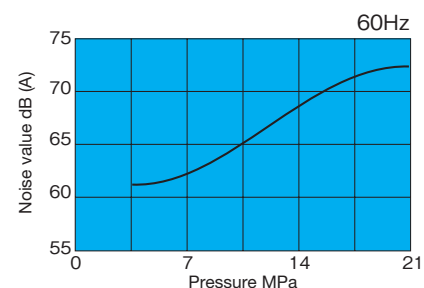
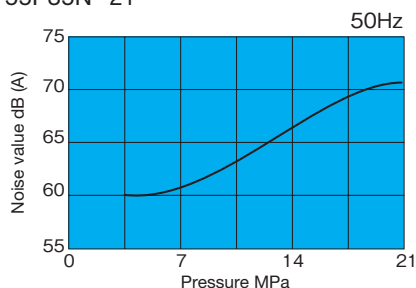

Selection Precautions

● Standard Accessories

A return filter with visual clogging inspection tool, and a fan cooler are equipped as standard.

● Options

- Options F* and R* cannot be selected for inclusion with an 8N* pump (NNP_***P8N* Type).
- For optional F* and R* blocks, up to three blocks can be specified for 01 size, and only one block can be specified for 03 size. Note, however, that the total weight of blocks and valves should not exceed 20kg.

· Tank Capacity 20ℓ, 30ℓ

Block Type	F1	F2	F3	F6	R1	R2	R3	R6
Block Weight (kg)	7.5	9.5	12.5	11.5	6.5	8.5	11.0	12.0
Allowable Additional Weight (kg)	12.5	10.5	7.5	8.5	13.5	11.5	9.0	8.0

· Tank Capacity 40ℓ, 60ℓ, 80ℓ

Block Type	F1	F2	F3	F6	R1	R2	R3	R6
Block Weight (kg)	8.5	11.0	14.0	11.5	7.0	9.5	12.0	12.5
Allowable Additional Weight (kg)	11.5	9.0	6.0	8.5	13.0	10.5	8.0	7.5

Note) M6 is the standard mounting tap for 03 size.

Handling Overview

● Hydraulic Operating Fluid

- Use general oil-based operating fluid equivalent to viscosity grade ISO VG32 or 46. Just contact us regarding options to petroleum based hydraulic operating fluid. The following is the viscosity grade and operating pressure.
 - Up to 7.0MPa: ISO VG32
 - 7.0MPa or higher: ISO VG46
- Contaminated operating fluid can lead to malfunction and shortened pump life. Manage operating fluid so that contamination is maintained at class NAS10 or lower.

● Startup Precautions

- Before starting the pump, inch the electric drive to make sure there is hydraulic fluid being sucked up.
- Check to make sure that the operating fluid in the tank is at the prescribed level.
 - Upper Limit Mark (Yellow): Prescribed fluid level (nominal capacity)
 - Lower Limit Mark (Red): Minimum fluid level
- Do not touch the surface of the pump while it is operating, it is very hot.

● Adjusting the Pressure and Discharge Rate

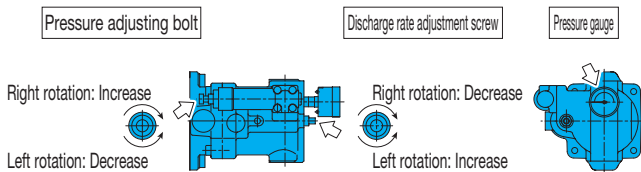

- 01, 03 size solenoid valves and modular valves can be selected.
- With option F* and R*, block and cylinder piping is hoses, configured by Nachi.
- Contact your agent for information about equipping a circuit.
- Option P is a bottom type oil pan. The oil pan does not have an oil drain port. The oil drain port is secured in place with the same mounting holes as the hydraulic unit.
- Option W is a leak test performed by Nachi.

● Circuit Configuration

- Allow for sufficient flexibility in the piping between the NN pack, external manifold, and actuator. (Hose with a length of 1 m or more is recommended.)

● Paint

- Nachi-Fujikoshi standard color: Mancel No. 5B6/3 (lacquer). However, the electric drive is Munsell No. N7.
- Contact your agent about specifying external paint colors.

● Electrical Wiring

- Perform electrical wiring exactly as shown below.

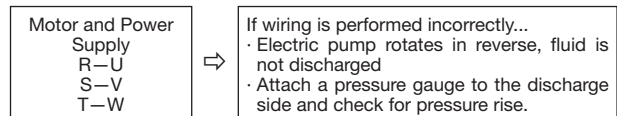

- Do not forget to ground the pump!
 - After wiring is complete, be sure to cover the terminal box with the cover that comes with it.
 - Do not forget to wire the fan motor of the fan cooler. The power supply is single-phase 200V AC, non-polarity.
- Provide a no fuse breaker on the main power supply to protect electric circuitry against shorts and other current leakage, and as protection against motor overload. Also provide a leak breaker to protect against the risk of electric shock, etc.

● Air Intake and Exhaust

- Take care so there is nothing blocking the area around air intake and exhaust of the pump drain fan cooler. Also, be sure to locate the pump in a well-ventilated area where heat will not build up.

● Transport and Installation

- Use the hangers when transporting the pump.
- Since this is a stationary type pump, secure it with bolts on a vibration-free, level surface.

● Maintenance and Inspection

- Oil Temperature: Use the pump in an area where the temperature is 10°C to 60°C.
- Operating Fluid Replacement Cycle: Perform the initial fluid replacement after three months of operation. After that, replace fluid when it becomes dirty or once a year, whichever comes first.
- Strainer and Tank Internal Inspection and Cleaning: Every three months
- Return Filter Element Inspection: Every three months (replace as required)
- Fan Cooler Fin Inspection and Cleaning: Every six months

● Environment

- Temperature: 10 to 35°C
- Avoid areas exposed to mist of water-soluble coolants, etc.